



**TRIMLINE
NP59 and TP59
SERIES**

***Keep This Manual
With Air Conditioner***



***AIR CONDITIONER
OPERATOR'S MANUAL***

CAUTION

**BEFORE INSTALLING AND
USING THIS AIR CONDITIONER,
IT IS IMPORTANT THAT THIS
MANUAL BE READ AND
UNDERSTOOD THOROUGHLY**

***KOOLTRONIC, INC.
30 Pennington-Hopewell Road
Pennington, NJ 08534
609•466-3400
FAX: 609•466-1114
www.kooltronic.com***

TABLE OF CONTENTS

		Page
I.	Introduction	2
II.	Incoming Inspection	3
III.	Product Handling	3
IV.	Product Identification Label	4
V.	Principles of Operation	5
VI.	Pre-Installation Testing	6
VII.	Specific Model Data	7 - 10
	Mounting	
	Drawings and Dimensions	
	Technical Data	
	Major Component Replacements	
	Wiring Schematics	
VIII.	Maintenance	11-12
IX.	Trouble Shooting	13
X.	Accessories	14
XI.	Warranty	15

I. Introduction

Kooltronic Air Conditioners are designed to provide a cool, dehumidified environment for your electronic components. There are models to fit virtually all sizes and shapes of electronics enclosures, in capacities ranging from 1,000 to 30,000 BTU/H. Our "closed-loop" design also ensures that your components will not be exposed to hot, dirty operating conditions.

This Manual provides you with the necessary general information for properly installing and operating standard Kooltronic Air Conditioners. Technical data and mounting instructions are presented on pages 7 through 10.

II. Incoming Inspection

Kooltronic Air Conditioners are designed, built and packaged to withstand the shock and vibration normally associated with shipment by common carriers. Occasionally improper handling during shipping causes damage. Such handling could include unbanding of palletized shipments, failing to respect "**This Side Up**" arrows, rough handling, falling off conveyors, excessive vibration, crushing, etc. Therefore, a thorough inspection should be done upon receipt of all shipments. Any carton tears, dents, scratches, loose articles or evidence of oil are signs of damage and should be noted on the Freight Bill. Cartons should be opened promptly and the units inspected for CONCEALED DAMAGE. Kooltronic Air Conditioners must be delivered in the proper mounting position to assure that damage to the compressor has not occurred during shipping. Any Kooltronic Air Conditioner that is delivered removed from the banded pallet, lying down or double stacked should be refused.

An immediate claim **MUST** be filed with the freight carrier and an inspection requested. Retain all packing materials. Kooltronic cannot assume responsibility for Consignee's failure to file a timely freight claim.

III. Product Handling:

- 1) Do not attempt to operate your Kooltronic Air Conditioner until you read and thoroughly understand this Manual. See section **VI PRE-INSTALLATION TESTING**.
- 2) Before operating the Kooltronic Air Conditioner be certain that it is placed in its correct mounting position. **All Air Conditioners containing an MM, NM, P, or V as part of the model number are designed to operate in a vertical position only. All Air Conditioners containing an H, RT or RM in the model number are designed to operate in a horizontal position only.** This placement must be done a minimum of 5 minutes prior to operating in order to allow the compressor oil to drain to the compressor sump area.

CAUTION

Kooltronic Air Conditioners must be operated in their proper mounting position. If attempts are made to operate a unit that is not in its designed mounting position, permanent compressor damage will occur. This action will void the warranty. To avoid compressor damage do not tip the unit more than 45° from its proper mounting position.

- 3) Before operating this unit, all electrical wiring must be checked to assure the proper connection to the correct power source. Minimum circuit ampacity should be at least 125% of the amperage found on the air conditioner label for the corresponding voltage. Do not exceed the maximum fuse size found on the label.
- 4) We do not recommend that Air Conditioners be shipped to their final destination attached to an enclosure. In the event that the Air Conditioner needs to be shipped attached to an enclosure it is strongly recommended that proper support be provided for the Air Conditioner. Excessive vibration can occur if Air Conditioners are not properly supported when shipped on enclosures, increasing the potential for internal damage and voiding the warranty.
- 5) **PROCEDURE FOR PROPER PACKING AND SHIPMENT OF KOOLTRONIC AIR CONDITIONERS:**
 - Keep Air Conditioner in proper upright position indicated by arrow markers.
 - Pack Air Conditioner in an appropriate carton (preferably original carton if possible), with adequate internal protective packaging, making sure carton is marked and is kept in correct upright position.
 - For local, controlled transportation, strap carton to a secure part of truck to prevent falling or sliding, minimize vibration, etc.
 - For common carrier shipment, band unit(s) securely to a pallet. Unpalletted shipment risks severe damage which voids the warranty.

IV. Product Identification and Labels

Each Kooltronic Air Conditioner includes an identification label. This label provides:

- ① Model Number
- ② Serial Number
- ③ Electrical power characteristics
- ④ Maximum and minimum ambient operating temperatures
- ⑤ Cooling capacity
- ⑥ Type and amount of refrigerant required for recharging
- ⑦ Design Pressure
- ⑧ Underwriters Laboratories Inc. Listed or Recognized Marks and NEMA ratings

We recommend you copy this information from your unit.

MODEL NO.			SERIAL NO.		
①				②	
VOLTS.	FREQ.	PH.	COOLING F.L.A.	AMBIENT TEMP. MIN. °F	MAX °F
③	③	③	③	④	④
COOLING BTU			REFRIGERANT		
⑤			⑥		
DESIGN PRESSURE P.S.I.G.			MAX. FUSE SIZE	⑧	
LOW	HIGH		③		
⑦	⑦				

SERVICE AIR FILTERS REGULARLY
ALLOW 5 MIN. BEFORE RESTARTING AFTER SHUTDOWN
UNAUTHORIZED SERVICE OR MODIFICATION VIOLATES WARRANTY
ALL MOTORS ARE THERMALLY PROTECTED

THIS PRODUCT IS PROTECTED BY ONE OR MORE OF THE FOLLOWING
PATENTS: 3,019,965 3,120,166 3,211,360 3,559,728 3,807,493 AND
OTHER PATENTS PENDING

MANUFACTURED BY:
KOOLTRONIC, INC. PENNINGTON, NJ VENTURA, CA

① ② When ordering parts, specify the Model Number and Serial Number.

③ Before operating, be sure that the power source matches these requirements.

④ Make sure that these parameters are met. Failure to do so may result in permanent damage to the unit

⑥ Use of incorrect type or amount of refrigerant will adversely affect performance and may damage the unit.

V. Principles of Operation

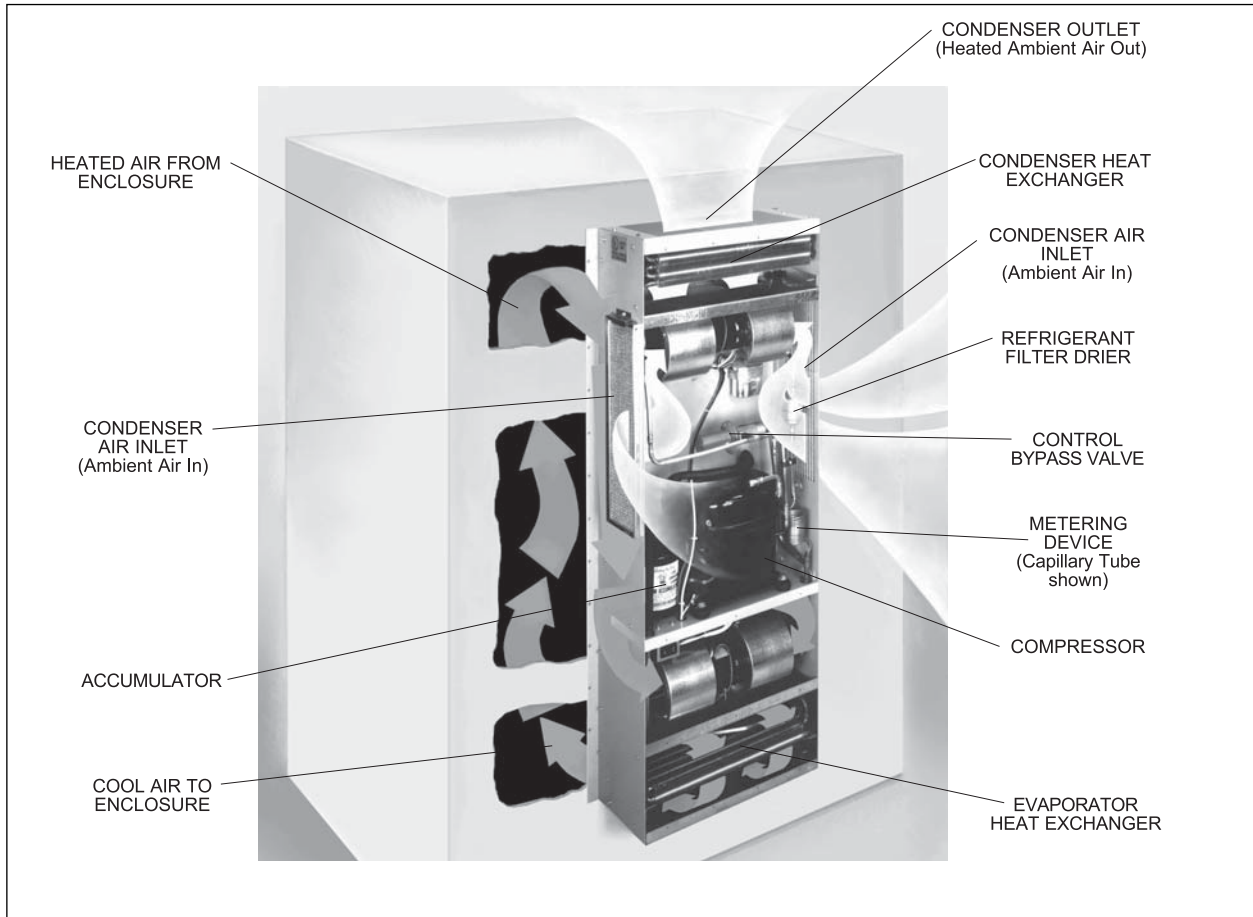

Kooltronic Air Conditioners are required when the equipment operating temperature must be kept near or lower than the ambient room temperature, and/or the cabinet must be sealed from dust, fumes, oil, corrosives and other contaminants. This Air Conditioner utilizes a “Closed-Loop Cooling System” to ensure optimum performance of the installed components.

Closed-Loop cooling seals the electronics enclosure from hostile elements in the environment. Two separate circulation systems are employed. The internal system cools and dehumidifies the air inside the cabinet, totally isolating the sensitive electronics and other components from the environment. The external system uses circulating ambient air or water to discharge the heat removed from the electronics. The heat is dissipated from the enclosure by means of the vapor compression refrigeration cycle. This takes place in a hermetically-sealed refrigeration system, utilizing either an air-cooled or water-cooled condenser heat exchanger. The warm air inside the enclosure is drawn through the evaporator coil where it is cooled, dehumidified and returned.

Any enclosure moisture accumulated on the evaporator coil is collected in the condensate tray and released to the ambient air through the drain tube or the condensate evaporator.

The heat removed through the evaporator coil is transferred by the compressed refrigerant to the condenser coil. Ambient air or water is then passed through the condenser coil, where it absorbs the heat and is then discharged to the environment.

The cool air discharge temperature is regulated by the capacity control (hot gas bypass) valve. The unit is equipped with a Low Temperature Thermostat to prevent over-cooling. In applications having frequent voluntary heat load fluctuations, an optional Compressor Short Cycle Protector is recommended.

VI. Pre-Installation Testing

Before mounting the air conditioner to the enclosure, test for proper operation. This will verify the shipping integrity of the system. Please follow the steps below prior to installation.

CAUTION

The Air Conditioner must be standing in its proper mounting position for a minimum of five (5) minutes prior to testing. Failure to follow this procedure will cause permanent damage to the compressor.

1. Allow the unit to sit in a upright position at a room temperature of 65°F minimum, allowing the system to warm-up particularly in winter months.
 2. Refer to the identification label for proper electrical voltage and current requirements. Then connect the power cord to a properly grounded and fused electrical supply. Leave the electrical power off.
 3. Note the factory thermostat setting which is typically 75 to 80°F.
 4. Adjust thermostat to its maximum setting.
 5. If your unit is equipped with an on-off switch, move it to the on position.
 6. Turn electrical power on.
 7. Verify that the evaporator blower or fan is running.
 8. Adjust the thermostat to its minimum setting. The compressor should start. On units equipped with a short cycle protector, the compressor will have a delayed start of 6 minutes from the time power is applied to the unit.
 9. Verify that the condenser blower or fan is running. Note, on units equipped with a low ambient kit, the start of the condenser fan or blower will be delayed until the system pressures rise.
 10. Operate the air conditioner for approximately ten (10) minutes. During this period no unusual noise or vibration should be evident. Both the evaporator and condenser fans or blowers should be delivering air through their respective discharge ports. The cool air should be discharged should be less than 70°F when the room temperature is between 70 and 80°F.
 11. On units equipped with heaters, adjust both the cooling and heating thermostats to their maximum settings. Verify that the compressor and condenser fan or blower has stopped. Verify elevated discharge air temperature from the evaporator air discharge.
 12. If your unit is equipped with an on-off switch, leave it in the on position. Return the cooling thermostat to its original setting. If unit is equipped with a heater, return the heating thermostat to its original position.
 13. Turn off the electrical power source, and disconnect the air conditioner from the power source.
 14. If any cover plug is removed to adjust the unit, make certain to put back in place to maintain the integrity of the closed-loop airflow system.
- NOTE:** Before shipment all Kooltronic, Inc. Air Conditioners are subjected to a performance test.

VII. Specific Model Data

Mounting

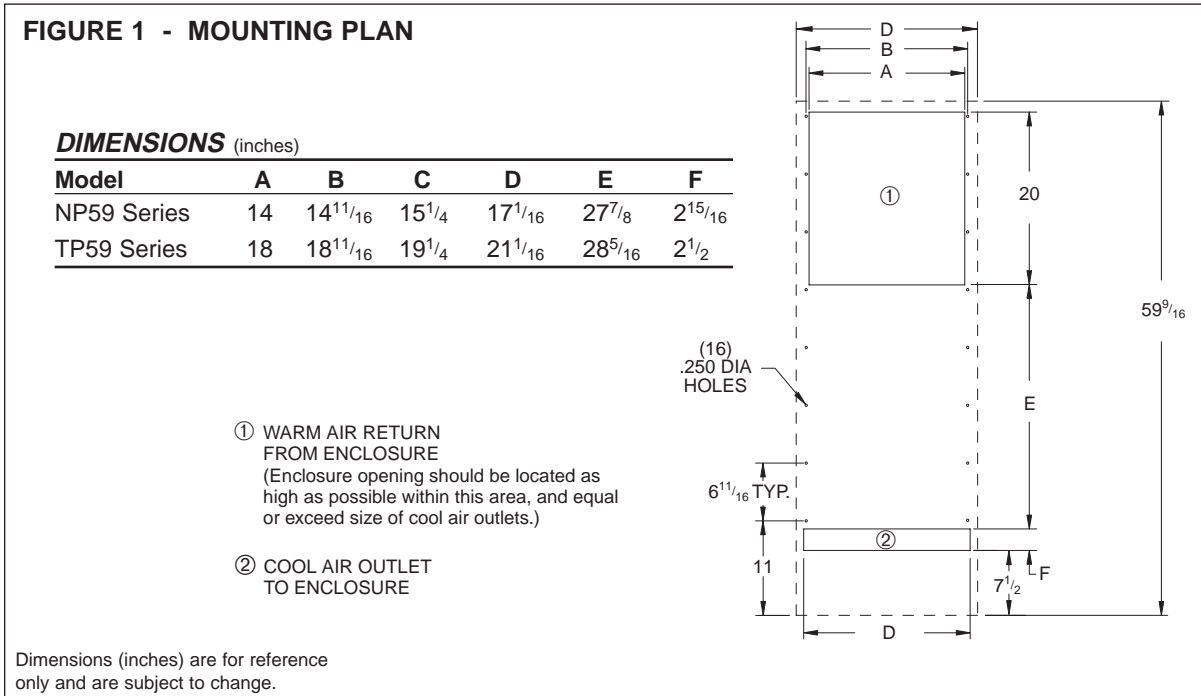

Kooltronic Air Conditioners have been engineered to be installed easily. To avoid damaging your Air Conditioner, please read the following information before installation:

1. Remove and save the four screws holding the Mounting Template and Assembly Bracket (M/TAB) to the unit. Remove the M/TAB.
2. See Figure 1 for proper M/TAB orientation. Place the M/TAB flush against the outside of the cabinet to locate cutouts and mounting holes.
3. NOTE: The top cutout for the warm air return does not have to match the full 9" opening on the M/TAB. You can locate your cutout anywhere within this opening. Locate your cutout close to the top and not less than 4" high. Make sure the cutouts don't interfere with components inside your cabinet.
4. Mount the M/TAB to the outside of the cabinet using all the mounting hardware supplied by Kooltronic (¹/₄"-20 screws/nuts/washers). NOTE: Make sure the screws are inserted with heads on M/TAB side. Tighten nuts securely.
5. Route the power cord through the top cut out in your cabinet. Mount the unit to the M/TAB by sliding the studs located on each side panel into the slots on the M/TAB.
6. Insert the remaining 10-32 screws and seal washers supplied by Kooltronic through the Air Conditioner side panel and into the M/TAB. To avoid misalignment of parts do not tighten any of the screws until they are all installed. Be careful not to overtighten the screws.
7. The drain hose must not be elevated above the exit port. Improper mounting will impede the flow of condensate and may cause internal malfunctions.

CAUTION

If the Air Conditioner is mounted to the cabinet door you must be sure that the door hinges will support the additional weight of the Air Conditioner. Also be certain that when the door is opened fully, the cabinet does not become unbalanced. The actual weight of the unit can be found in the performance specifications.

Drawings and Dimensions

NP59 and TP59 SERIES

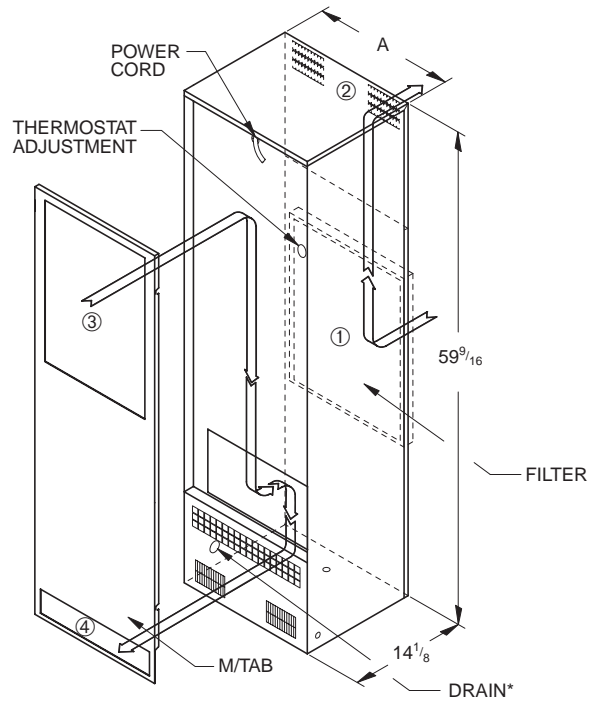

- ① FILTERED CONDENSER AIR INLET (Ambient Air In)
- ② CONDENSER OUTLET (Warm Ambient Air Out)
- ③ WARM AIR RETURN FROM ENCLOSURE (Enclosure opening should be located as high as possible within this area, and equal or exceed size of cool air outlets.)
- ④ COOL AIR OUTLET TO ENCLOSURE

DIMENSIONS (inches)

Model	A
NP59 Series	17 ³ / ₁₆
TP59 Series	21 ³ / ₁₆

* Other drain outlets are available - contact KOOLTRONIC

Dimensions (inches) are for reference only and are subject to change.

Technical Data

Model	** BTU/H Rating	Ambient Temp. °F Max./Min.	◇ Volts	◇ Hz	** Running Amps	Approximate Weight (lbs.)
<u>NP59 Series</u>						
K2A3C14NP59R	14000	125/50	230/200	60/50	22.0/22.3	250
K2A3C14NP59R5	14000	125/50	230	50	19.8	250
K2A3C16NP59R	16000	125/50	230/200	60/50	22.0/22.3	250
K2A3C16NP59R5	16000	125/50	230	50	19.8	250
K2A3C18NP59R	18000	125/50	230/200	60/50	22.0/22.3	250
K2A3C18NP59R5	18000	125/50	230	50	19.8	250
K2A3C20NP59R	20000	125/50	230/200	60/50	22.0/22.3	250
K2A3C20NP59R5	20000	125/50	230	50	19.8	250
<u>TP59 Series</u>						
K2A3C18TP59R	18000	125/50	230/200	60/50	22.0/22.3	265
K2A3C18TP59R5	18000	125/50	230	50	19.8	265
K2A3C20TP59R	20000	125/50	230/200	60/50	22.0/22.3	265
K2A3C20TP59R5	20000	125/50	230	50	19.8	265
K2A3C22TP59R	22000	125/50	230/200	60/50	22.0/22.3	265
K2A3C22TP59R5	22000	125/50	230	50	19.8	265
K2A3C24TP59R	24000	125/50	230/200	60/50	22.0/22.3	265
K2A3C24TP59R5	24000	125/50	230	50	19.8	265

Units in **BOLD** are current standard products. Other units are prior product offerings and shown for reference only.

* Switchable. Switch is internally-mounted for security.

** Rating shown is for operation at maximum ambient temperature.

◇ 115V, 60 Hz and 230V, 60 Hz models also perform at full capacity when operated at 100V, 50 Hz or 200V, 50 Hz respectively. No transformer is required.

Major Component Replacements

Part	K2A3C_NP59 Part Number	K2A3C_TP59 Part Number
Compressor	0665-50	0665-50
Compressor Capacitor	0452-54	0452-54
Condenser Blower Motor	0261-80	0261-80
Condenser Blower Motor Capacitor	0452-06	0452-06
Condenser Blower Assembly	609059-00-38	609059-00-38
Evaporator Blower Motor	0261-54	0261-54
Evaporator Blower Motor Capacitor	0452-03	0452-03
Evaporator Blower Assembly	6015-00-130	6015-00-130
Filter	20001F	20001F

NOTE: Part Numbers shown are for 60Hz/1Ø. For 50Hz consult Kooltronic.

Standard Features

Built-in Condensate Evaporator
EMI/RFI Suppressor
Low-ODP Refrigerant
Low Temperature Control Thermostat

M/TAB Mounting System
NEMA 12 Rating Maintained (UL50)
Reversible Condenser Outlet Blower
UL/CUL Recognized

Wiring Schematic

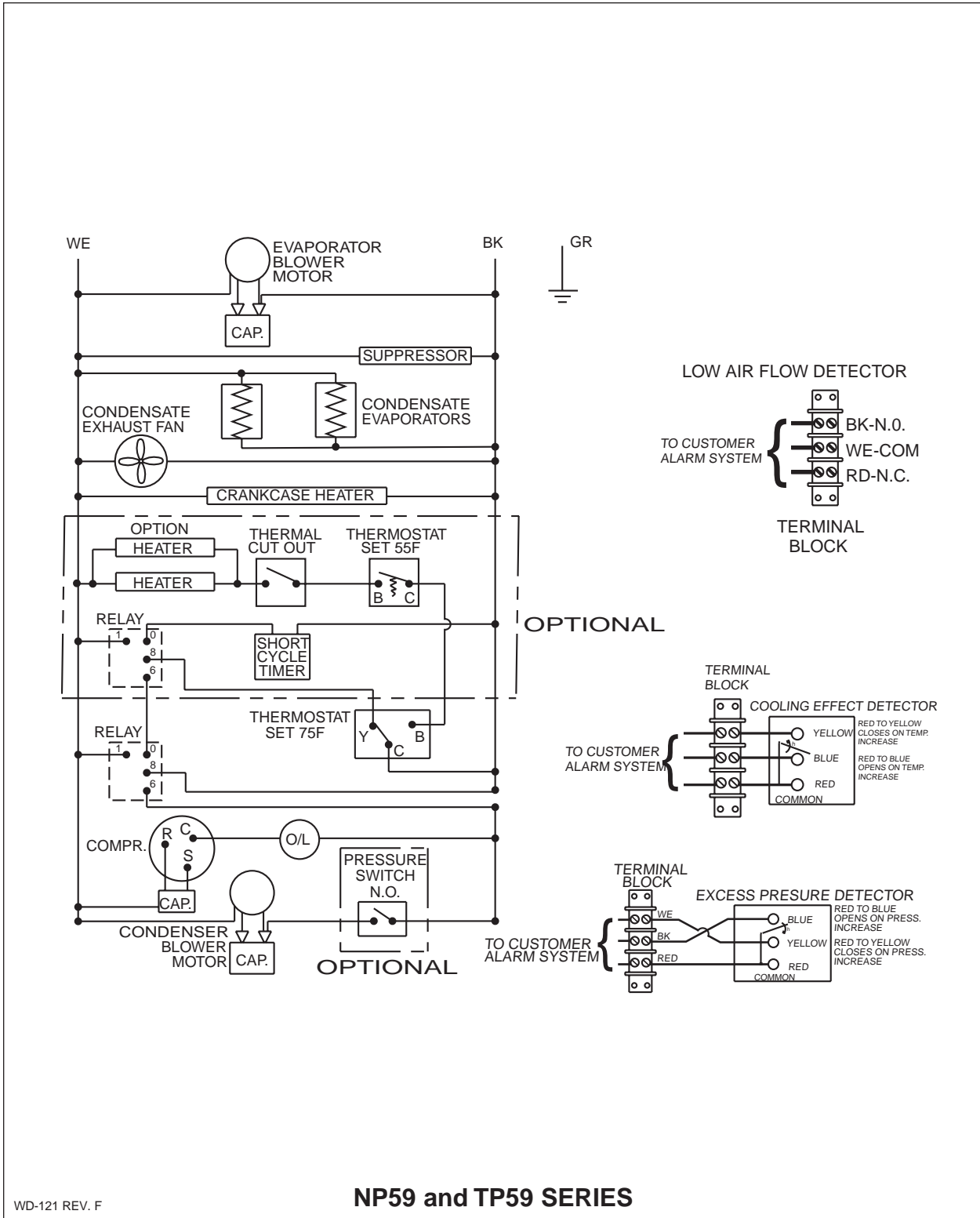

WD-121 REV. F

NP59 and TP59 SERIES

VIII. Maintenance

Kooltronic Water-Cooled Air Conditioners require no maintenance. Air-Cooled Air Conditioners are designed to require only the routine cleaning of air filters to assure unimpeded air flow through the condenser heat exchanger. It is not possible to recommend specific filter cleaning intervals since the level and the nature of airborne particulate matter differs widely with each installation. It is generally sufficient to remove and wash the reusable aluminum mesh air filters when the outer surfaces of these filters appear covered with a thin layer of dust or lint. Filter recoating adhesive is recommended. Appropriate disposable filters are available from Kooltronic.

If filter service is neglected or delayed, the air conditioner will not perform at its design capacity. The first indication of excessively clogged air filters is usually a gradual increase of temperature within the equipment cabinet. If operation is continued under these conditions, the compressor will be shut off by the thermal overload device. The compressor will restart when its external temperature drops below the protector threshold setting and the compressor will continue to cycle on and off. Continued operation under these conditions will cause damage, shorten compressor life and void the warranty.

A. Filter Removal and Service

Kooltronic Air Conditioners feature an easily removable inlet filter to facilitate necessary cleaning.

CAUTION

Do not operate the Air Conditioner for extended periods of time with the filter removed. The condenser coil may become clogged with dust or lint from the air entering the face. A clogged condenser coil is not readily detected and will give the same reaction as a clogged filter. A clean filter is the best protection.

- 1) Lift the filter, using the attached tab, to clear the lower filter retainer. Pull filter toward you and downward until the top of the filter clears the upper filter retainer.
- 2) After removal, the filters should be flushed under warm running water with the clean side up, driving contaminants out the dirty side of the filter. If the accumulated dirt is oily, washing in a detergent bath is recommended, followed by a warm water rinse as above.
- 3) The filters may be sprayed with **Kooltronic A-16 Filter Recoating Adhesive** to trap fine airborne contaminants, or they may simply be dried and reinstalled as strainer type filters. **Recoating is recommended for best results.**
- 4) Reinstall the filter: (a) keeping the tab at the bottom, slide filter into the upper retainer, (b) press filter against the unit and (c) slide down into lower retainer.

B. Blowers

The design life of the blowers employed in all Kooltronic Air Conditioners is substantially in excess of 20,000 hours. All Kooltronic condenser and evaporator blowers are equipped with UL/CSA permanently-lubricated precision ball-bearing motors, with automatic-reset thermal overload protectors.

CAUTION

Before opening the Air Conditioner, disconnect all power.

If field replacement of a blower motor is necessary, most blower assemblies, including mounting plate, are readily removable. Each of the blower mounting plates is held to the air conditioner cabinet structure by screws and nuts. For installation of the replacement blower, electrical connections may be broken at the terminal block, or power leads may be cut and appropriately spliced together.

C. Compressor

All Kooltronic compressors are approved by UL and CSA, and require no maintenance. They are hermetically sealed and charged at the factory, and equipped with automatic-reset thermal overload protectors.

If the compressor or the hot gas bypass valve fails, it is strongly recommended that the Air Conditioner be returned to Kooltronic for service.

D. Refrigerant Loss

Kooltronic Air Conditioners are subjected to a series of tests to detect refrigerant leaks, during and after manufacture. It is possible that shipping or other damage, or microscopic leaks over a long period, may result in the need for replenishment of refrigerant charge. **When it has been verified by a qualified professional that a refrigerant shortage does exist, the leak must be repaired. Then the unit may be evacuated and recharged in the field by qualified service people only.**

CAUTION

Refer to the data on the unit name plate which specifies the type of refrigerant and the amount of charge in ounces.

E. Relocation

If your Kooltronic Air Conditioner has to be moved to another location by truck, the following precautions should be taken:

- De-mount Air Conditioner from equipment, controller or enclosure.
- Conform to the applicable provisions of PROCEDURE FOR PROPER PACKING AND SHIPMENT OF KOOLTRONIC AIR CONDITIONERS in this manual under *Section III. "PRODUCT HANDLING"*.

IX. Trouble-Shooting

Each Kooltronic Air Conditioner is engineered for performance and built for reliability. They are designed to require no routine maintenance other than the cleaning of ambient air filters. If your air conditioner should require service, we have compiled a trouble-shooting chart to assist your service personnel. If additional assistance is required contact Kooltronic at 609 • 466-3400.

Problem	Cause	Solution
Unit not Cooling	No Power	Check Power Source and Electrical Connections
	Loss of Refrigerant	Locate and repair leak
	Evaporator or Condenser Blower not operating	Replace Motor, Capacitor or entire Assembly
	Filter clogged	Clean or replace Filter
	Clogged Evaporator or Condenser Coil	Clean Coil
	Low Temperature Control (Thermostat) improperly set	Lower setting until unit starts
	Low Temperature Control (Thermostat) defective	Replace Thermostat or Relay when applicable
Ice on Evaporator Coil	Failed Compressor	Replace Compressor
	Insufficient Heat Load or Unit Oversized for Application	Contact Kooltronic
	Failed Evaporator Blower	Replace Evaporator Blower Motor or Assembly
Condensate draining continuously	Clogged Evaporator Coil	Clean Coil
	Enclosure not properly sealed	Check and seal all openings
Excessive vibration	Excessive opening of Enclosure	Eliminate the frequency of door opening
	Defective Motor in Blower	Replace Motor
	Defective Wheel in Blower	Replace Wheel
Compressor Inoperative	Compressor Loose	Tighten Mounting Bolts
	Low line Voltage	Check Nameplate Voltage against supply
	Loss of Compressor Oil	Replace Compressor
	Loss of Refrigerant	Locate and repair leak
	Failed Compressor Capacitor	Replace Capacitor
	Thermal Overload	Contact Kooltronic
Refrigerant or Oil leaks	Power interruptions	Allow Compressor time to reset
	Crack or pin hole in tubing or brazed joint	Replace tubing or rebraze joint

X. Accessories

Accessories and Options	Air Cooled							Water Cooled	
	Panel Mounted						Rack Mounted (H & V)	Horizontal Top Mounted (HT)	Panel Mounted (WP)
	Mini		P24 P28 P36	P47 P52 P59*	NP33 NP36 NP47 NP59				
	MM SM	HS NM NP17							
Adapter Plate for Rack Mounting	•	N/A	N/A	N/A	N/A	N/A	N/A	N/A	
Air Deflectors	•	•	•	•	•	•	•	N/A	
Airflow Switch	• ^E	N/A	•	•	•	•	•	•	
Compressor Heater	•	•	•	•	•	•	•	•	
Condenser Access Panel	N/A	N/A	N/A	•	N/A	N/A	N/A	•	
Condensate Evaporator Kit	• ^F	Std.	•	•	Std.	• ^B	Std.	•	
Cooling Effect Detector	• ^A	•	•	•	•	•	•	•	
Deep Drain Pan Kit	X	N/A	• ^C	•	N/A	Std.	Std.	•	
Excess Pressure Detector	• ^A	•	• ^D	•	•	•	•	•	
Filter Recoating Adhesive	•	•	•	•	•	•	•	N/A	
Filters for replacement	•	•	•	•	•	•	•	N/A	
Internal Corrosion Resistance	•	•	•	•	•	•	•	•	
Lifting Eyes	N/A	N/A	•	•	•	•	•	•	
Low Airflow Detector	• ^E	N/A	•	•	•	•	•	•	
Low Ambient Kit	X	X	X	•	X ^K	X	X	N/A	
Low Temperature Control	• ^A	Std.	•	•	Std.	•	•	•	
M/TAB**	N/A	Std. ^H	N/A	N/A	Std.	N/A	N/A	N/A	
Mounting Hinge	•	N/A ^J	•	•	N/A	N/A	N/A	•	
Rear Condenser Air Inlet Panel	Std.	Std. ^H	Std.	•	Std.	N/A	N/A	N/A	
Refrigerant Charging Kit	•	•	•	•	•	•	•	•	
Short Cycle Protector	• ^A	•	•	•	•	•	•	•	
Special External Paint Finishes	•	•	•	•	•	•	•	•	
Special Line Cord or Connectors	•	•	•	•	•	•	•	•	
Surge Suppressor	•	Std.	•	•	Std.	•	•	•	
Switchable Power (50/60Hz)	•	•	•	•	•	•	•	•	
Unit Heaters	X	• ^G	•	•	•	•	•	•	
Weather Protection Kit	•	•	•	•	•	•	•	N/A	

- Available
- * 18,000-22,000 BTU/H P59 accessories and options same as NP59
- ** Mounting Template & Assembly Bracket
- X Not available due to design configuration

- A Micro-Mini has internal space available for only one of these options. All others are mounted externally.
- B Standard on H models
- C Standard on P24
- D Not available on P24 series

- E N/A on Micro-Mini
- F Standard on Super-Mini
- G N/A on Narrow-Mini
- H N/A on HS
- J Available on NP17
- K Available on NP59

CONDENSATE EVAPORATOR KIT: This device attaches to bottom of Air Conditioner. Condensate is collected, vaporized and discharged to ambient.

COOLING EFFECT DETECTOR: A thermostat is mounted inside the cabinet and attached to a sensor in the warm air return. When the air temperature increases to a set point, a signal is sent to a terminal block. Requires user-installed wiring to a warning device.

EXCESS PRESSURE DETECTOR: Monitors head or condensing pressure within the Air Conditioner. When the pressure reaches an unsafe level a switch sends a signal to the terminal block. Requires user-installed wiring to a warning device.

LOW TEMPERATURE CONTROL: Recommended in situations of extremely low ambient temperatures and/or low internal loads. At a pre-set return air temperature, the Thermostat shuts down the unit, except for the evaporator blower, for continuous cabinet air circulation.

SHORT CYCLE PROTECTOR: Protects the compressor from damage due to harmful short cycling after a power interruption. Protector keeps compressor off for 5 to 6 minutes before resumption of operation.

WEATHER PROTECTION KIT: For outdoor installations subject to invasion by rain, snow or windblown dirt, special deflectors shield the condenser air inlet and outlet ports.

XI. Standard Warranty

KOOLTRONIC products are warranted to be free of defects in workmanship, materials and components. The following warranty periods apply from date of shipment:

- Air moving devices/components and hermetic system components: 1 year
- Spare parts, except filters: 90 days

The above warranty applies when the equipment is operated under the following conditions:

- Ambient temperature not in excess of 125°F (52°C) in normal atmosphere or as stated on product nameplate
- Voltage variation no greater than $\pm 10\%$ from nameplate rating
- Frequency variation no greater than $\pm 3\text{Hz}$ from nameplate rating
- Maximum cooling load no higher than air conditioner nameplate rating
- Waiting five minutes before restarting air conditioner after intentional or accidental shutoff
- Compliance to all other installation, maintenance and operating instructions, as supplied
- The purchaser assumes the responsibility of grounding the unit and installing it in accordance with local electrical and safety codes, as well as the National Electric Code (NEC) and OSHA

KOOLTRONIC cannot assume responsibility for mis-application of its products or the erroneous selection of an inappropriate product by a non-authorized KOOLTRONIC representative. Our applications engineers will gladly assist in the selection of the proper product, provided all required details of the application are furnished.

THIS WARRANTY CONSTITUTES THE ENTIRE WARRANTY WITH RESPECT TO THE PRODUCT AND IS IN LIEU OF ALL OTHERS, EXPRESSED OR IMPLIED, INCLUDING ANY WARRANTY OF MERCHANTABILITY AND WARRANTY OF FITNESS FOR A PARTICULAR PURPOSE AND IN NO EVENT IS KOOLTRONIC RESPONSIBLE FOR ANY CONSEQUENTIAL DAMAGES OF ANY NATURE WHATSOEVER.

RETURN AUTHORIZATION (RA) PROCEDURE

- All returns require a Return Authorization number whether the return is for warranty or non-warranty repair, rotation of stock, damage or any other reason. Returns without an RA number will be refused.
- Customer must call KOOLTRONIC After Sale Kare (ASK), Pennington, New Jersey (609 • 466 • 3400) to obtain an RA number, or email ask@kooltronic.com.
- The following information is required when an RA is requested:
 - Original customer Purchase Order number and date
 - Date product was received by customer
 - Number of parts to be returned
 - Product description, model and serial number
 - Reason for return
 - Action requested
 - Contact name, telephone, FAX numbers and e-mail address
- Pack unit in a suitable container for shipment, preferably the

KOOLTRONIC assumes no liability beyond the repair or replacement of its own product. This Warranty does not cover:

- Labor or reimbursement of labor for evaluation, removal, installation, repair, or cost of any warranted part, unless authorized in writing by KOOLTRONIC
- Use of equipment for other than its designed purpose or operating conditions
- Operation in harsh, oily, corrosive or other abnormal environmental conditions, without the proper filtration, sealing, protective coatings and/or weather protection
- Damage to hermetic system resulting from continuous operation with dirty or clogged air filters or improper or negligent maintenance
- Use of refrigerant other than designated
- Customer modification or abuse
- Shipping damage or other accident (Claims for shipping damage are the responsibility of the customer. Timely claims must be filed by the customer with the freight carrier)
- Cracked or broken hermetic tubing, brazed joints or other internal damage caused by shipping or mishandling
- Damage caused by shipping units attached to an enclosure
- Any and all conditions resulting from noncompliance with the preceding operating conditions
- Returned freight must be paid by customer
- **This standard warranty does not apply to custom products. Consult your KOOLTRONIC representative for limitations**

original packaging if available. All Air Conditioners must be returned in an upright position properly secured to a pallet. **Improper packaging may void warranty claim.** If an Air Conditioner is received laying down or shipped via UPS or similar small parcel service the warranty will be void.

- Mark carton prominently with KOOLTRONIC's Return Authorization Number.
- Enclose all pertinent documents.
- Freight charges on all products returned to KOOLTRONIC shall be paid by the customer. Unauthorized collect shipments will be refused.
- If a unit is repaired under Warranty, KOOLTRONIC will pay the freight charges both ways within the Continental USA at KOOLTRONIC's negotiated rates. Warranty repaired units will be returned to customer at KOOLTRONIC expense only within the Continental USA.
- All authorized returns are subject to a restocking fee.