



***Keep This Manual
With Heat Exchanger***

*Find additional information on
this model at kooltronic.com or
use the Technical Documents
QR code below.*

*Technical
Documents*



KPHE30 SERIES WATER-TO-AIR HEAT EXCHANGER

OPERATOR'S MANUAL

CAUTION

**BEFORE INSTALLING AND
USING THIS HEAT EXCHANGER,
IT IS IMPORTANT THAT THIS
MANUAL BE READ AND
UNDERSTOOD THOROUGHLY**



***KOOLTRONIC, INC.
30 Pennington-Hopewell Road
Pennington, NJ 08534
609•466-3400
FAX: 609•466-1114
www.kooltronic.com***

TABLE OF CONTENTS

		Page
I.	Introduction	2
II.	Incoming Inspection	3
III.	Product Handling	3
IV.	Product Identification and Nameplate	3
V.	Principles of Operation	4
VI.	Specific Model Data	4-6
	Mounting	
	Drawings and Dimensions	
	Technical Data	
	Major Component Replacements	
	Accessories	
	Wiring Diagram	
VII.	Maintenance	7
VIII.	Packing Procedure	7
IX.	Warranty	8

I. Introduction

Kooltronic Heat Exchangers are designed to provide a cool environment for your electronic or electrical components. There are models to fit virtually all sizes and shapes of electrical or electronic enclosures. Our “closed loop” design also ensures that your components will not be exposed to hot, dirty operating conditions.

This Manual provides you with the necessary general information for properly installing and operating Kooltronic Heat Exchangers. Unit specific technical data and mounting instructions are presented later in the Manual.

II. Incoming Inspection

Kooltronic Heat Exchangers are designed, built, and packaged to withstand the shock and vibration normally associated with shipment by common carriers. Occasionally improper handling during shipping causes damage. Such handling could include unbanding of palletized shipments, failing to respect any carton handling instructions, falling off conveyors, excessive vibration, crushing, etc. Therefore, a thorough inspection should be done upon receipt of all shipments. Any carton tears, dents, scratches, or loose articles should be noted on the Freight Bill. Cartons should be opened promptly and the units inspected for CONCEALED DAMAGE.

An immediate claim MUST be filed with the freight carrier and an inspection requested. Retain all packing materials. Kooltronic cannot assume responsibility for Consignee's failure to file a timely freight claim.

III. Product Handling

- Do not attempt to operate your Kooltronic Heat Exchanger until you read and thoroughly understand this Manual.
- Before operating this unit, all electrical wiring must be checked to assure the proper connections.

CAUTION

Operate this unit only on the proper voltages and frequencies as noted on the nameplate.

IV. Product Identification and Nameplate

Each Kooltronic Heat Exchanger includes an identification nameplate. This nameplate provides:

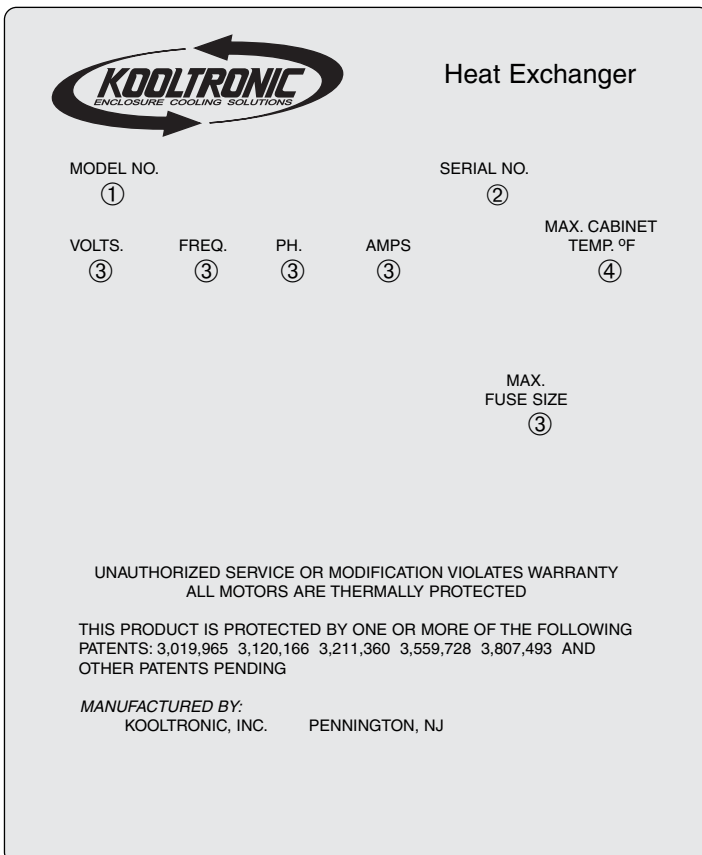

- ① Model Number
- ② Serial Number
- ③ Electrical power characteristics
- ④ Maximum ambient operating temperature

We recommend you copy this information from your unit.

①② When ordering parts, specify the Model Number and Serial Number.

③ Before operating, be sure that the power source matches these requirements.

④ Make sure that these parameters are met. Failure to do so may result in permanent damage to the unit

V. Principles of Operation

If ambient air cannot be utilized directly as a cooling medium, another cost-effective method of cooling is a Water-to-Air system (below). Water is used to remove heat from the air circulated within the electronics enclosure.

Cooling water is circulated through a tube-and-fin coil. As the heat-laden air circulates through the coil, the heat is absorbed by the water and carried away, in a continuous process.

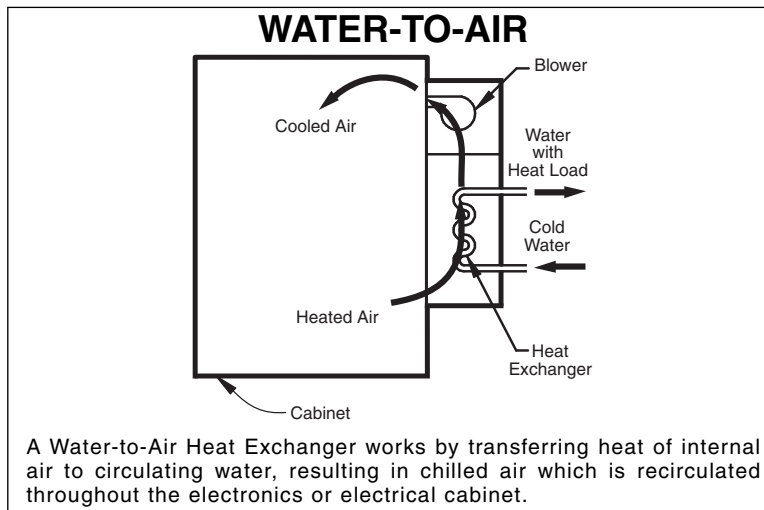

Figure 1

Water-to-Air systems are easy to install and usually require minimum maintenance. The water used must be reasonably clean and cold enough to ensure proper operation of the cooling system under the most severe anticipated conditions. In some cases, if sufficiently cold water is available, below-ambient-temperature cooling can be achieved.

The Heat Exchanger with options -- Automatic Water Flow Control is shown on Figure 2.

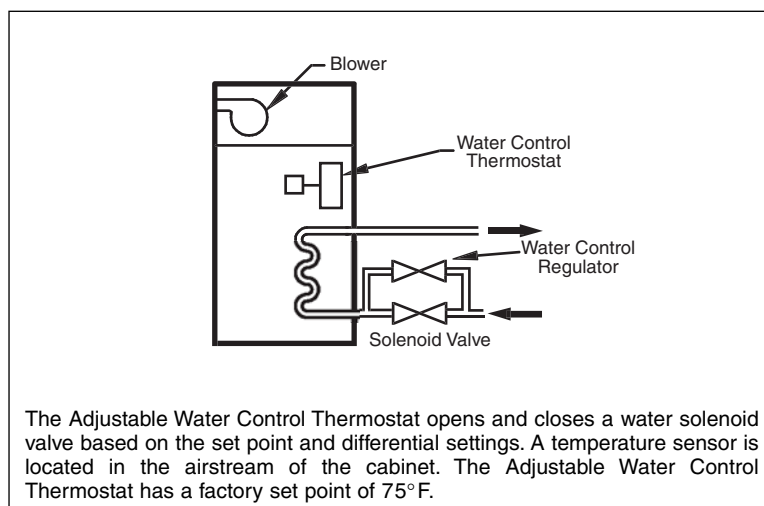
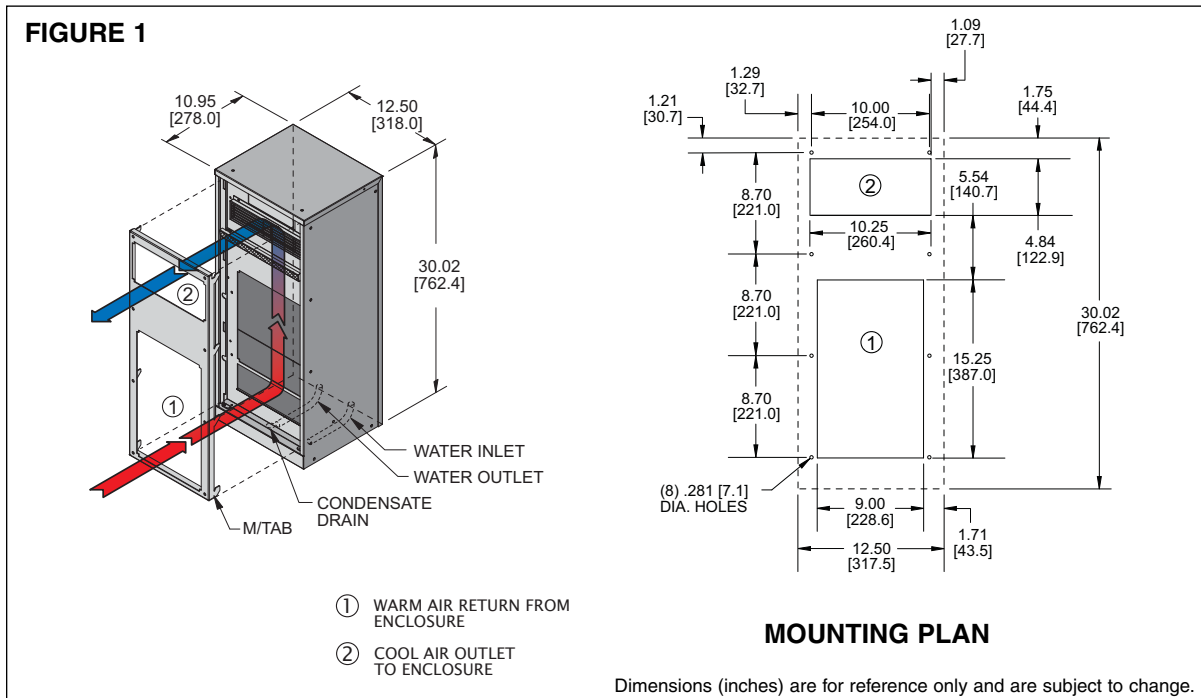

Figure 2

VI. Specific Model Data

Mounting



Kooltronic Heat Exchangers have been engineered to be installed easily. To avoid damaging your Heat Exchanger, please read the following information before installation:

1. Loosen the two screws on the bottom holding the Mounting Template and Assembly Bracket (M/TAB) to the unit. Remove the M/TAB.
2. See Figure 1 for proper orientation. Place the M/TAB flush against the outside of the cabinet to locate cutouts and mounting holes.
3. **Make sure the cutouts don't interfere with components inside your cabinet.**
4. Mount the M/TAB to the outside of the cabinet using all the mounting hardware supplied by Kooltronic (1/4-20 screws/nuts/washers). Preferred positions: one in each corner and two near center on each side. NOTE: Make sure the screws are inserted with heads toward you. Tighten nuts securely.
5. Route the power cord through the top cut out in your cabinet. Mount the unit to the M/TAB by sliding the slots on the bulkhead into the hooks on the M/TAB. After unit is in place, tighten 2 screws at bottom of unit. These two screws will force the M/TAB into studs on side panel for a tight seal.
6. Attach overflow drain hose supplied to the drain exit at the bottom of the unit. This hose must not be elevated above the exit port. Improper mounting will impede the flow of condensate and may cause internal malfunctions.

Technical Data

Model	Volts	Amps	Watts	Performance		Approx. Weight (lbs.)
				1 gpm	2gpm	
KPHE30	115	1.16	133	58	74	53
K2PHE30	230	0.57	128	58	74	53

Note: The rating Watts/°F is the heat dissipation divided by temperature difference between maximum air temperature in enclosure and water temperature entering the heat exchanger.

Major Component Replacements

	<u>KPHE30</u>	<u>K2PHE30</u>
	Part Number	Part Number
Blower	0194-14	0194-15
Capacitor	0452-06	0452-73
Coil	0666-32	0666-32

NOTE: Part Numbers shown are for 60Hz/1Ø. For 50Hz consult Kooltronic.

Options

- Automatic Water Flow Control
- Cooling Effect Detector
- High Water Level Detector
- Internal corrosion resistant coatings
- Low Airflow Detector
- Other voltages and frequencies
- Special materials or finishes
- Special motors, line cords or connectors

Wiring Diagram

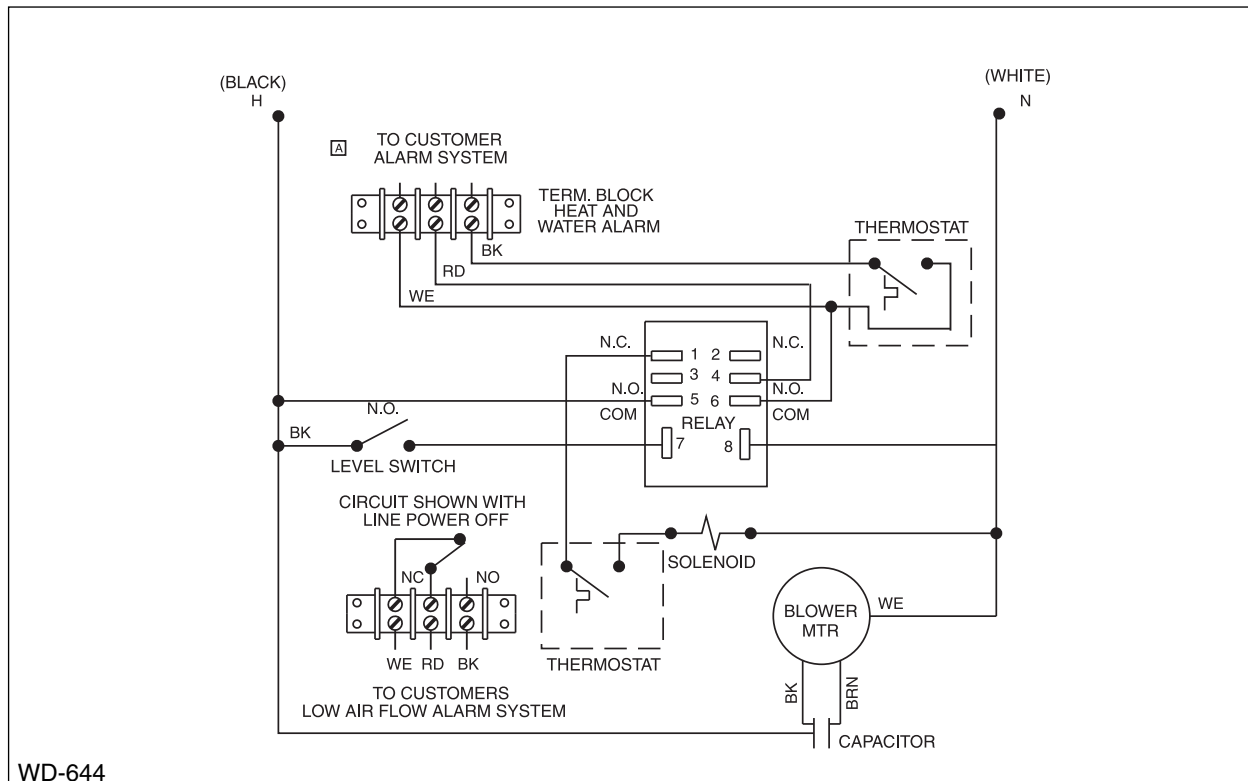

WD-644

VII. Maintenance

In general, very little maintenance or repair is required on Water-to-Air Heat Exchangers.

CAUTION

Disconnect electric power from the Heat Exchanger before servicing unit.

Blowers - Removable for Repair or Replacement

In Water-to-Air Heat Exchangers, powerful blowers are used. Each is carefully chosen to provide optimum airflow characteristics for component cooling as well as heat transfer within the unit.

Each of these air moving devices has been engineered and constructed to provide years of trouble-free operation and thus require no periodic maintenance.

In the case of air mover failure, blowers are easily removable with simple tools.

Replacement Blower Assemblies and Motors are generally readily available from Kooltronic stock.

Please see the listing of Major Component Replacements earlier in this Manual.

CAUTION

Do not handle or carry the blower by inserting fingers into the blower opening where wheels are located. This could cause a wheel misalignment problem and create an out-of-balance condition. Also, the sharp vanes could result in injury.

VIII. Packing Procedure

- Keep Heat Exchanger in proper upright position.
- Pack Heat Exchanger in an appropriate carton (preferably original carton if possible), with adequate internal protective packaging, making sure carton is marked properly.
- For local controlled transportation, strap carton where possible, to a secure part of truck to prevent falling or sliding, minimizing vibration, etc.
- For common carrier shipment, band unit(s) securely to a pallet. Unpalletized shipment risks severe damage which voids the warranty.

IX. Standard Warranty

KOOLTRONIC products are warranted to be free of defects in workmanship, materials and components. The following warranty periods apply from date of shipment:

- Air moving devices/components and hermetic system components: One year
- Non-operating parts, except filters: 5 years

The above warranty applies when the equipment is operated under the following conditions:

- Ambient temperature not in excess of 125°F (52°C) in normal atmosphere or as stated on product nameplate
- Voltage variation no greater than $\pm 10\%$ from nameplate rating
- Frequency variation no greater than $\pm 3\text{Hz}$ from nameplate rating
- Maximum cooling load no higher than air conditioner nameplate rating
- Waiting five minutes before restarting air conditioner after intentional or accidental shutoff
- Compliance to all other installation, maintenance and operating instructions, as supplied
- The purchaser assumes the responsibility of grounding the unit and installing it in accordance with local electrical and safety codes, as well as the National Electric Code (NEC) and OSHA

KOOLTRONIC cannot assume responsibility for mis-application of its products or the erroneous selection of an inappropriate product by a non-authorized KOOLTRONIC representative. Our applications engineers will gladly assist in the selection of the proper product, provided all required details of the application are furnished.

THIS WARRANTY CONSTITUTES THE ENTIRE WARRANTY WITH RESPECT TO THE PRODUCT AND IS IN LIEU OF ALL OTHERS, EXPRESSED OR IMPLIED, INCLUDING ANY WARRANTY OF MERCHANTABILITY AND WARRANTY OF FITNESS FOR A PARTICULAR PURPOSE AND IN NO EVENT IS KOOLTRONIC RESPONSIBLE FOR ANY CONSEQUENTIAL DAMAGES OF ANY NATURE WHATSOEVER.

RETURN AUTHORIZATION (RA) PROCEDURE

- All returns require a Return Authorization number whether the return is for warranty or non-warranty repair, rotation of stock, damage or any other reason. Returns without an RA number will be refused.
- Customer must call the KOOLTRONIC Customer Service Department, Pennington, New Jersey (609 • 466 • 3400) to obtain an RA number.
- The following information is required when an RA is requested:
 - Original customer Purchase Order number and date
 - Date product was received by customer
 - Number of parts to be returned
 - Product description, model and serial number
 - Reason for return
 - Action requested
 - Contact name, telephone, FAX numbers and e-mail address
- Pack unit in a suitable container for shipment, preferably the

KOOLTRONIC assumes no liability beyond the repair or replacement of its own product. This Warranty does not cover:

- Labor or reimbursement of labor for evaluation, removal, installation, repair, or cost of any warranted part, unless authorized in writing by KOOLTRONIC
- Use of equipment for other than its designed purpose or operating conditions
- Operation in harsh, oily, corrosive or other abnormal environmental conditions, without the proper filtration, sealing, protective coatings and/or weather protection
- Damage to hermetic system resulting from continuous operation with dirty or clogged air filters or improper or negligent maintenance
- Use of refrigerant other than designated
- Customer modification or abuse
- Shipping damage or other accident (Claims for shipping damage are the responsibility of the customer. Timely claims must be filed by the customer with the freight carrier)
- Cracked or broken hermetic tubing, brazed joints or other internal damage caused by shipping or mishandling
- Damage caused by shipping units attached to an enclosure
- Any and all conditions resulting from noncompliance with the preceding operating conditions
- Returned freight must be paid by customer
- **This standard warranty does not apply to custom products. Consult your KOOLTRONIC representative for limitations**

original packaging if available. All Heat Exchangers must be returned in an upright position properly secured to a pallet. **Improper packaging may void warranty claim.** If a Heat Exchanger is received laying down or shipped via UPS or similar small parcel service the warranty will be void.

- Mark carton prominently with KOOLTRONIC's Return Authorization Number.
- Enclose all pertinent documents.
- Freight charges on all products returned to KOOLTRONIC shall be paid by the customer. Unauthorized collect shipments will be refused.
- If a unit is repaired under Warranty, KOOLTRONIC will pay the freight charges both ways within the Continental USA at KOOLTRONIC's negotiated rates. Warranty repaired units will be returned to customer at KOOLTRONIC expense only within the Continental USA.
- All authorized returns are subject to a restocking fee.