

GUARDIAN/GUARDIANX SERIES DP21 NEMA 4/4X AIR CONDITIONER

Model	Normally In Stock	NEMA Rating	BTU/H Rating	95/95 Rating	Ambient Temp.			Volts	Hz	* Running Amps	Approx. Weight		
					°F Max.	°C Min.	°C Max.				lbs	kg	
KNA4C3DP21L	Yes	4	3000	2470	131	-20	55	-29	115/100	60/50	6.0/5.0	54	25
KNA4C3DP21LV	Yes	4X	3000	2470	131	-20	55	-29	115/100	60/50	6.0/5.0	54	25

* Rating shown is for operation at maximum ambient temperature.

STANDARD FEATURES

- Baked Powder Finish (NEMA 4 models)
- Built-in Condensate Evaporator
- CFC-Free Refrigerant
- Closed-Loop Cooling
- Compressor Short Cycle Protector
- Condenser Blower Controller
- Epoxy-Coated Condenser and Evaporator Coils
- Filter
- Heavy-duty Steel Shell (NEMA 4 models)
- Internal Corrosion Protection (NEMA 4X models)
- NEMA 4 or 4X Rating Maintained (UL50)
- Programmable Temperature Alarm
- Programmable Thermostat
- Six-Foot [1.8m] (minimum) 3-Wire Power Cord
- Stainless Steel Shell (NEMA 4X models)
- UL/CUL Listed

ACCESSORIES AND OPTIONS

- Enclosure Heater
- Filter Recoating Adhesive
- Lead-Lag Controller
- Remote Monitoring
- Remote Thermostat Relay
- Replacement Filters
- Special materials or finishes
- Special motors, line cords or connectors



NEMA TYPE 4/4X MAINTAINED

PERFORMANCE

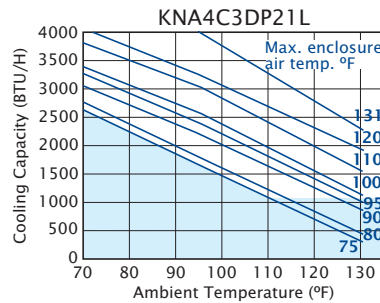

Operation within shaded area not recommended.

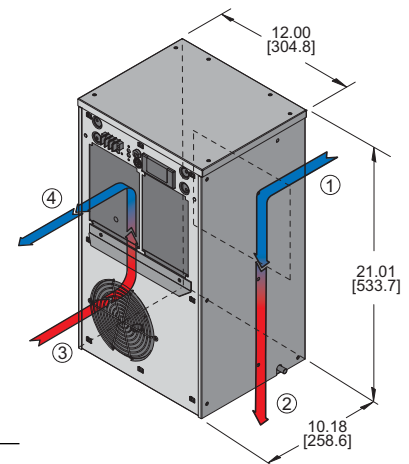

DRAWINGS

Dimensions, inches [mm], are for reference only and are subject to change.

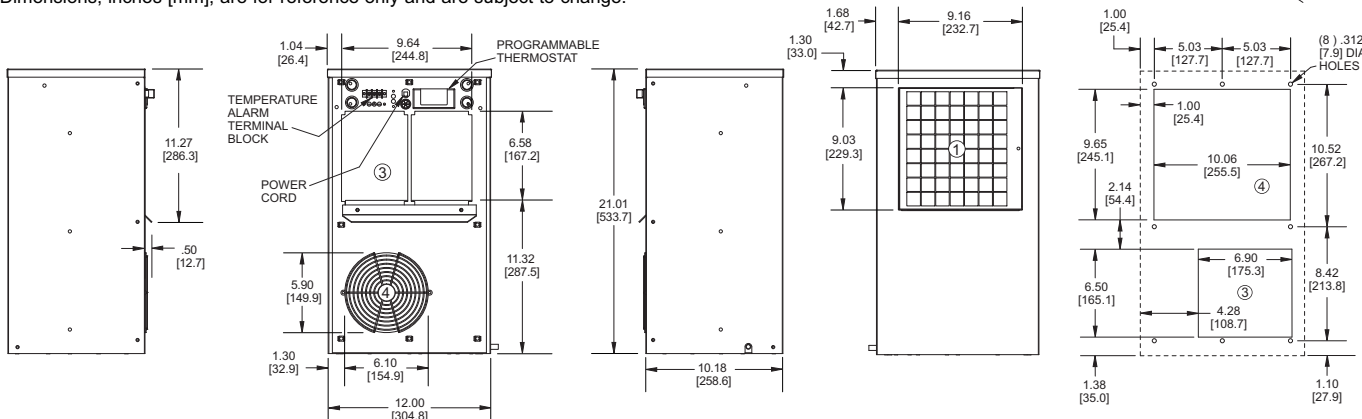

- ① CONDENSER AIR INLET (Ambient Air In)
- ② CONDENSER OUTLET (Warm Ambient Air Out)
- ③ WARM AIR RETURN FROM ENCLOSURE
- ④ COOL AIR OUTLET TO ENCLOSURE

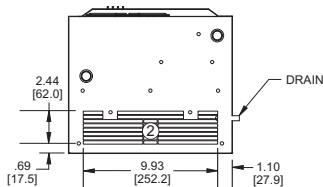

Many popular units are available as 3D solid models for customer system integration. Please contact Kooltronic for details.

dpm21.qxd 6/27/17

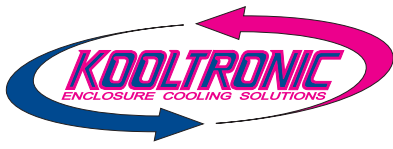

GUARDIAN/GUARDIANX SERIES DP21 NEMA 4/4X AIR CONDITIONER

DESCRIPTION

The **Guardian/GuardianX** Indoor/Outdoor Air Conditioners are designed specifically for **NEMA 4** and **4X** enclosure applications that require washdown or are subject to outdoor storm conditions. All **Guardian** models have a **NEMA 4** Rating, offering protection against the hazards of unwanted environmental penetration. The **GuardianX**, with a **NEMA 4X** Rating, is available with a Stainless Steel Shell and Internal Corrosion Protection.

With Epoxy-coated condenser coils and a closed-loop cooling system, the **Guardian Series** offers added security by providing an operating environment safe from harsh ambient conditions.

The features engineered into all of the **Guardian Series** models make them a tamper-resistant choice for external applications. Combined with a NEMA 4 Rating, with all models UL/CUL Listed, the **Guardian Series** is an excellent choice for telecommunications or other outdoor cabinet applications.

FEATURES AND BENEFITS (STANDARD)

All models UL/CUL Listed, a standard of safety.

Built-in condensate evaporator eliminates the need for a drain (normal operation*).

CFC-free refrigerant provides a zero ozone depletion potential.

Closed-loop cooling provides stable temperature control while excluding dust and humidity from the electrical enclosure.

Compressor short-cycling protection extends compressor life.

Condenser impeller cycling provides stable capacity and temperature control.

Condenser filtration to maintain peak thermal performance extends compressor life.

Internal corrosion protection to increase reliability in hostile environments.

NEMA 12, 3R & 4 ratings for compatibility with listed electrical enclosures.

Programmable thermostat capable of remote monitoring and control.

Programmable temperature alarm to alert if early action required.

Stainless steel shell for NEMA 4X corrosive environments (NEMA 4X models).

Both evaporator and condenser coils are epoxy coated, prolonging unit life.

* May not be adequate in extremely high humidity with open or leaky enclosure. Overflow condensate drain fitting and hose are included.

FEATURES AND BENEFITS (OPTIONAL)*

Enclosure heater eliminates damaging condensation, increasing reliability of electrical enclosure components.

Lead-lag control for two air conditioners provides for capacity control, and alternates usage, increasing reliability.

Mounting adapter plates are offered to replace another manufacturer's unit.

Remote monitoring provides temperature data for warning of early action required.

Remote thermostat relay for control by a user-supplied control system.

Special paint finishes.

*Contact KOOLTRONIC for more information.

REPLACEMENT FILTERS

The DP21 filter Part No. 8388F (8.38" x 8.88" x 0.38" [212.8mm x 225.5mm x 9.7mm])