

Model	NEMA Rating	Normally In Stock	UL/CUL Listed or Recognized	BTU/H Capacity	95/95 Rating BTU/H	Ambient Temp. °F Max./Min.	Volts	Hz	** Running Amps	Approx. Weight (lbs.)
KNA4C5DP33L	4	Yes	Listed	5000	4000	131/-20	115/100	60/50	10.6/10.2	95
K2NA4C5DP33L	4		Listed	5000	4000	131/-20	230/200	60/50	4.5	95
KNA4C5DP33LV	4X	Yes	Listed	5000	4000	131/-20	115/100	60/50	10.6/10.2	95
K2NA4C5DP33LV	4X		Listed	5000	4000	131/-20	230/200	60/50	4.5	95

** Rating shown is for operation at maximum ambient temperature.

STANDARD FEATURES

- Built-in Condensate Evaporator
- CFC-Free Refrigerant
- Condenser Impeller Speed Controller
- EMI/RFI Suppressor
- Epoxy-Coated Condenser Coils
- Heavy-duty Steel Shell
- Internal Corrosion Protection (NEMA 4X models)
- Low Temperature Control Thermostat
- NEMA 4 or 4X Rating Maintained (UL50)
- Six-Foot [1.8m] (minimum) SJT 3-Wire Power Cord
- Stainless Steel Shell (NEMA 4X models)
- Textured Baked Powder Finish
- UL/CUL Listed

ACCESSORIES AND OPTIONS

- Cooling Effect Detector
- Enclosure Heater
- Filter
- Filter Recoating Adhesive
- Lead-Lag Controller
- Other voltages and frequencies
- Remote Thermostat Relay
- Replacement Filters
- Short-Cycle Protector
- Special materials or finishes
- Special motors, line cords or connectors



NEMA
TYPE 4 OR 4X
MAINTAINED

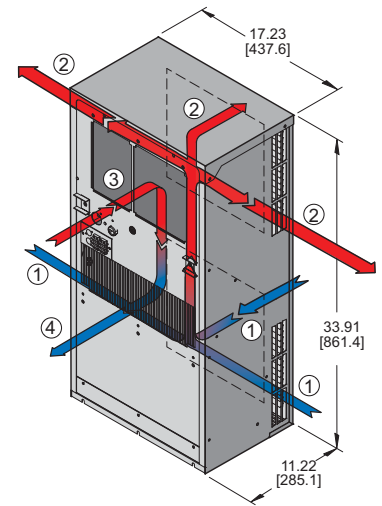

PERFORMANCE

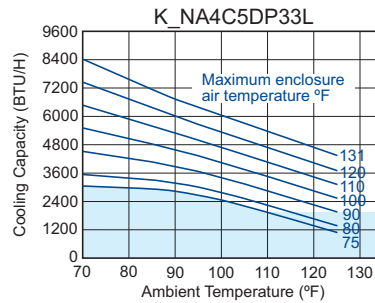

- ① CONDENSER AIR INLET (Ambient Air In) (3 sides)
- ② CONDENSER OUTLET (Warm Ambient Air Out)
- ③ WARM AIR RETURN FROM ENCLOSURE
- ④ COOL AIR OUTLET TO ENCLOSURE

DRAWINGS

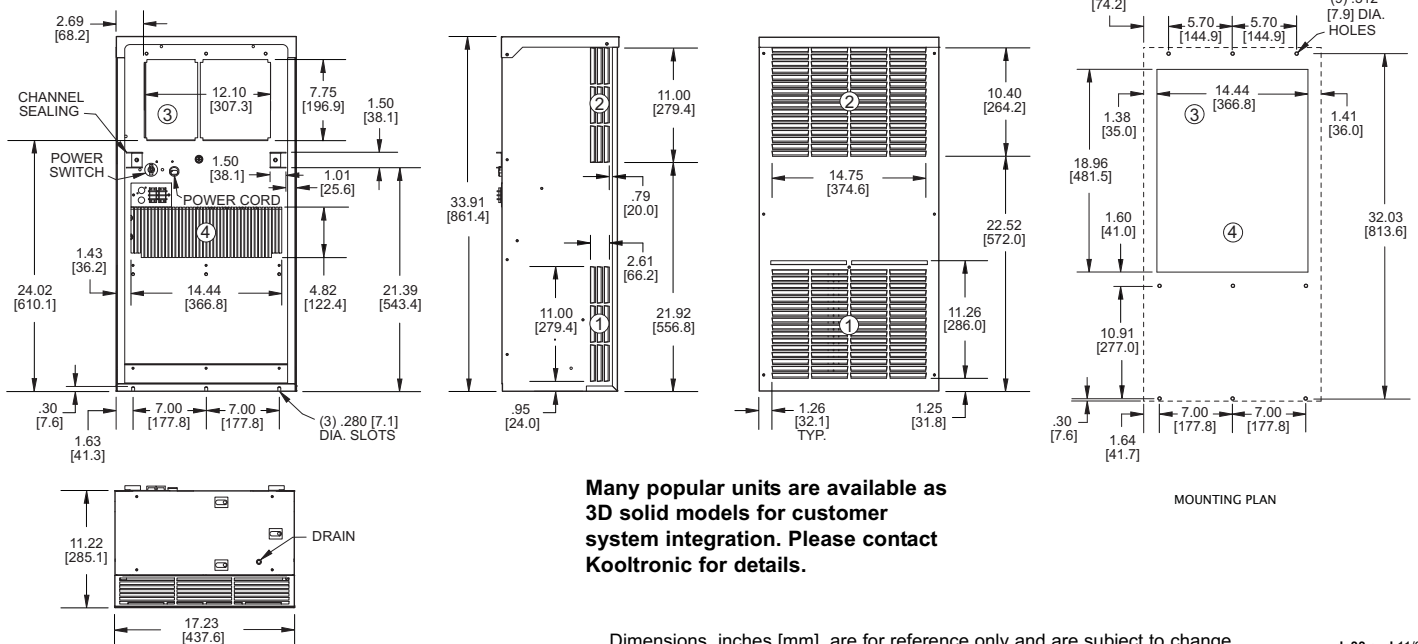

DESCRIPTION

The **Guardia/GuardianX** Indoor/Outdoor Air Conditioners are designed specifically for **NEMA 4** and **4X** enclosure applications that require washdown or are subject to outdoor storm conditions. All **Guardian** models have a **NEMA 4** Rating, offering protection against the hazards of unwanted environmental penetration. The **GuardianX**, with the **NEMA 4X** Rating, is available with a Stainless Steel Shell and Internal Corrosion Protection.

With Epoxy-coated condenser coils and a closed-loop cooling system, the **Guardian Series** offers added security by providing an operating environment safe from harsh ambient conditions.

The features engineered into all of the **Guardian Series** models make them a tamper-resistant choice for external applications. Combined with a NEMA 4 Rating, with all models UL/CUL Listed, the **Guardian Series** is an excellent choice for telecommunications or other outdoor cabinet applications.

STANDARD FEATURES

CLOSED-LOOP COOLING: The enclosure interior airflow system is isolated from the ambient airflow system. Ambient air can not invade the cool, dehumidified sensitive component compartment.

CONDENSER IMPELLER SPEED CONTROLLER: A solid state sensor reacting to the condenser coil temperature modulates the condenser impeller between minimum and maximum speed based on the coil temperature. This reduces noise levels, fan cycling, compressor cycling and prevents the unit from freezing.

EMI/RFI SUPPRESSOR: EMI/RFI Suppressor minimizes transient line spikes during on/off cycling.

EPOXY-COATED CONDENSER COILS: Condenser Coils in the **Guardian Series** models are Epoxy-Coated. This coating will withstand 1000 hours of salt spray per the ASTM B 117 test method. **NOTE:** Severe operational environments such as waste water treatment and salt spray are likely to cause corrosion failure over a period of time regardless of coating. **Warranty:** Corrosive conditions may effect the warranty coverage. Consult factory for warranty limitations in corrosive environments.

GASKETING: All units are fully gasketed for tight, leakproof installation, in compliance with the NEMA 4 Enclosure Rating.

HEAVY-DUTY STEEL SHELL: Precision-engineered heavy gauge steel construction of all shells and blowers insures Air Conditioners will stand up under tough applications.

INSULATION: All cold components, lines and the evaporator compartment are insulated with high-performance insulation for maximum efficiency.

LOW TEMPERATURE CONTROL THERMOSTAT: Thermostatic Low Temperature Control prevents over-cooling and provides energy-efficient operation.

POWER: Available in 115 VAC, 60 Hz or 50/60 switchable and 230 VAC, 50 Hz or 60 Hz.

POWER CORD: All models have six foot [1.8m] SJT-type 3-wire power cords with appropriate plugs.

QUALITY ASSURANCE: Refrigeration system components are kept sealed until charged with refrigerant; all brazed joints are thoroughly leak-tested; each unit is functionally tested before shipment.

REFRIGERANT: CFC-free R134a Refrigerant is used in the **Guardian DP33** Air Conditioners.

TEXTURED BAKED POWDER FINISH: Durable, baked-on textured beige powder finish is standard. Other finishes are available.

UL/CUL LISTED: The **Guardian/GuardianX DP33** is UL/CUL Listed.

ACCESSORIES AND OPTIONS*

COOLING EFFECT DETECTOR: A thermostat is mounted inside the cabinet and attached to a sensor in the warm air return. When the air temperature increases to the set point, a signal is sent to a terminal block. User-installed wiring from the terminal block to local and/or remote warning devices (*light, bell, siren, etc.*) can be for normally open or closed operation.

ENCLOSURE HEATER: 120V or 240V fin strip heater, installed singly or ganged, used to maintain desired internal enclosure temperature, under cold operating conditions.

FILTER RECOATING ADHESIVE: This compound is a superior product for recoating filters after washing. The adhesives penetrate dirt layers to keep the filter surface tacky for longer effective performance between washings.

INTERNAL CORROSION PROTECTION: An air cured coating is sprayed on copper lines and brazed joints on the condenser side, providing a degree of protection from corrosive environments. This coating will withstand 1000 hours of salt spray per the ASTM B 117 test method. Also see Stainless Steel Cabinet or Integrity NEMA 4/4X Air Conditioners. **NOTE:** Severe operational environments such as waste water treatment and salt spray are likely to cause corrosion failure over a period of time regardless of coating. **Warranty:** Corrosive conditions may effect the warranty coverage. Consult factory for warranty limitations in corrosive environments. **NOTE:** For additional corrosion protection options, contact factory. Internal Corrosion Protection and Stainless Steel Shell are necessary in order to maintain **NEMA 4X** Rating for **GuardianX DP33**.

Other voltages and frequencies*

REPLACEMENT FILTER: Filter consisting of a multi-layer grid of sturdy corrugated aluminum, securely held in a one-piece aluminum frame. The DP33 optional filter Part No. 9501F (9.50" x 10.50" x 0.38" [241.3mm x 266.7mm x 9.7mm])

SHORT CYCLE PROTECTOR: Protects the compressor from possible damage due to harmful short cycling, by initiating an "off" period before resumption of normal operation. This option is particularly recommended for applications where interlocked cabinet doors are utilized, where the cabinet internal loads fluctuate across a wide range or ambient air temperatures vary significantly throughout the day.

STAINLESS STEEL SHELL: For applications in corrosive or other hostile environments where chemical/moisture combinations are present. Stainless Steel Shell and Internal Corrosion Protection are necessary in order to maintain **NEMA 4X** Rating for **GuardianX DP33**.

Special materials or finishes*

Special motors, line cords or connectors*

*Contact KOOLTRONIC for more information.