



K2BC2E225/40A IMPELLER BLOWER

TECHNICAL DATA

Model	CFM@ Cutoff		Volts	Hz	Amps	Watts	Capacitor		RPM	Min. Temp.	Max. Temp.
	0" S.P.	S.P.					µF	RPM			
K2BC2E225/40A	559	1.8	230	60	0.55	100	2.0	2610	-4°F/-20°C	140°F/60°C	
K2BC2E225/40A	535	1.7	230	50	0.41	91	2.5	2465	-4°F/-20°C	140°F/60°C	



STANDARD FEATURES

- Low noise level
- 559 CFM capacity
- Available in 230 VAC, 50/60Hz
- Compact size
- Precision balanced
- External rotor design
- Precision ball-bearing motors
- Class F, thermally protected
- Galvanized Steel impeller
- UL Recognized
- Normally in-stock

ACCESSORIES*

- Capacitor - P/N: 50Hz. - 0452-81/
60Hz. - 0452-64
- Inlet Ring - P/N: 1114-07
- Automatic Speed Control

***Note:** This unit requires a capacitor for operation. Capacitors are sold separately and shipped loose for field installation by customer. An Inlet Ring is recommended for optimum performance. These are sold separately, to be installed by the customer.

PERFORMANCE

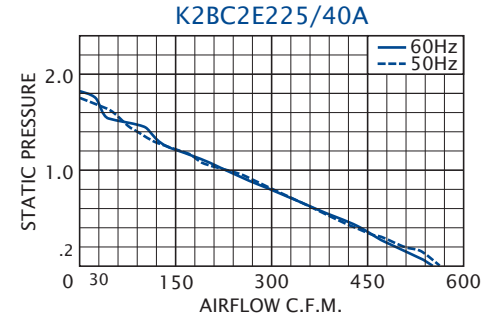

Airflow vs. static pressure curves are shown for 60 Hz and 50 Hz (broken line) inputs. Static pressure is in inches of water.

DRAWINGS

Dimensions, inches [mm], are for reference only and are subject to change.

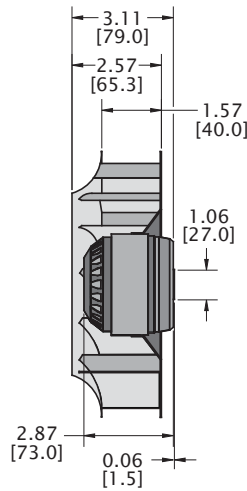
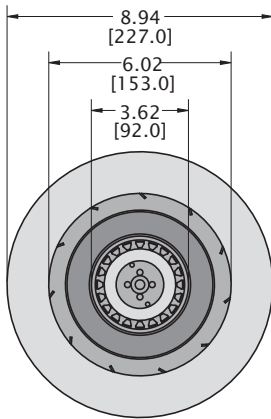

An inlet ring, which must be installed by the customer, is recommended for optimum performance. This unit requires a capacitor which must be mounted and connected by the customer.

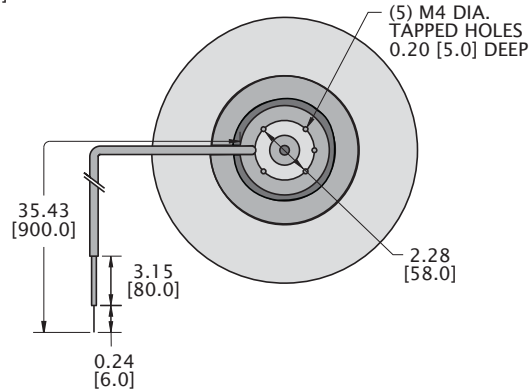

INLET RING P/N: 1114-07

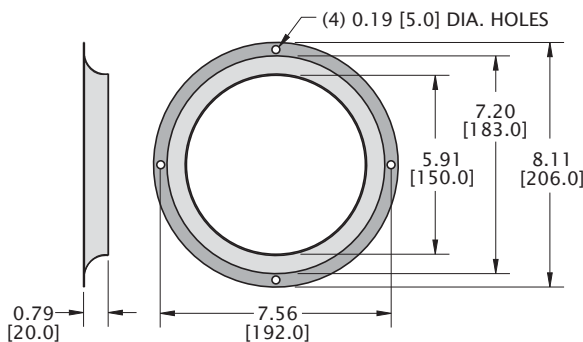

TYPICAL INSTALLATION

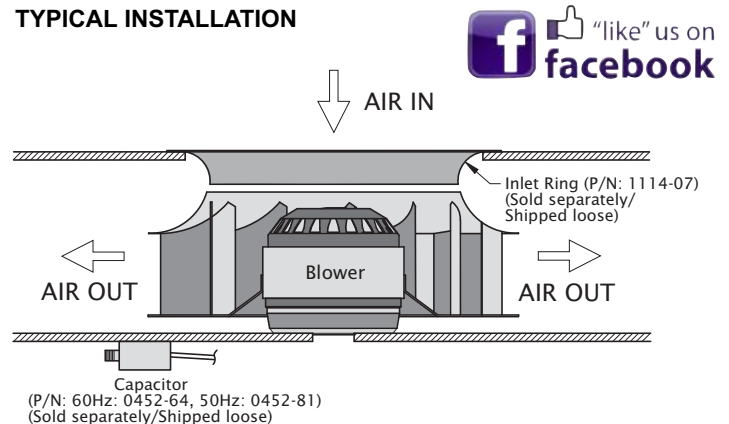

k2bc2e220-40a.qxd 8/24/17