



NARROW-MINI TRIMLINE AIR-COOLED PANEL-MOUNTED AIR CONDITIONERS

with Serial Numbers E18A1604 and above



TECHNICAL DATA

Model	NEMA Rating	UL/CUL Listed or Recognized	BTU/H Capacity	95/95 Rating BTU/H	Ambient Temp		Volts	Hz	Running Amps	Fuse Amps	Approx. Weight	
					°F Max./Min.	°C Max./Min.					lbs	kg
KA4C2.5NML	12	Listed	2900	2400	120/50	49/10	115	60	5.0	15	38	18

Rating shown is for operation at maximum ambient temperature.



STANDARD FEATURES

- Built-in Condensate Evaporator
- CFC-Free Refrigerant
- Closed-Loop Cooling
- Compressor Short Cycle Protector
- Epoxy-Coated Evaporator Coils
- Filter
- NEMA 12 Rating Maintained (UL50)
- Programmable Temperature Alarm
- Programmable Thermostat
- UL/CUL Listed

ACCESSORIES AND OPTIONS

- Adapter
- Aluminum Shell
- Filter Recoating Adhesive
- High-Capacity Condensate Evaporator
- Internal Corrosion Protection
- Lead-Lag Controller
- Lifting Eyes
- M-Tab Mounting (for existing retrofits)
- Remote Monitoring
- Remote Thermostat Relay
- Replacement Filters
- Special motors, line cords, or connectors
- Stainless Steel Shell
- Weather Protection Kit

PERFORMANCE

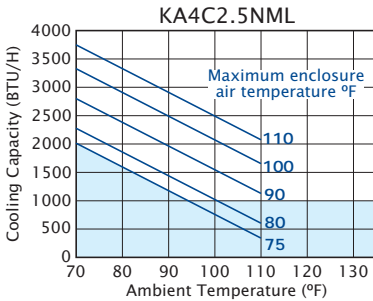

Operation within shaded area not recommended.

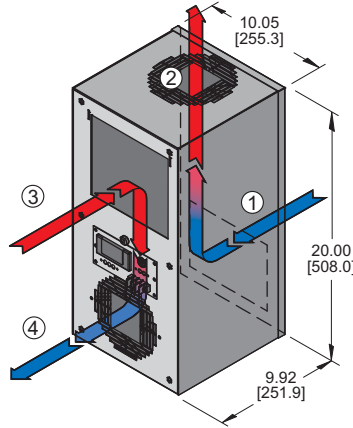

Find additional information on this model at kooltronic.com, or use the Technical Documents QR code below.

Technical Documents

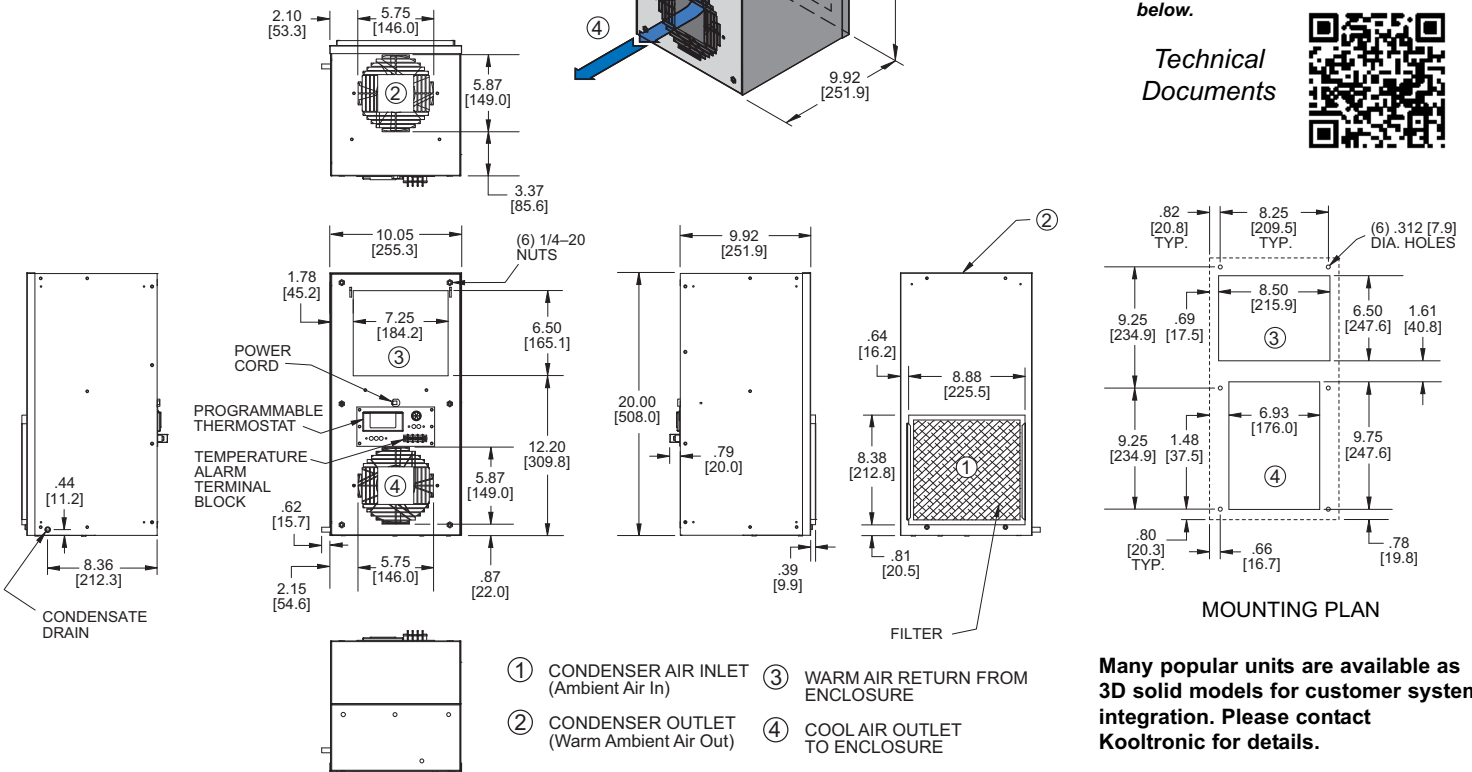

Many popular units are available as 3D solid models for customer system integration. Please contact Kooltronic for details.

Dimensions, inches [mm], are for reference only and subject to change.

nm.qxd (7/29/19) (CDR: 20179)



NARROW-MINI TRIMLINE AIR-COOLED PANEL-MOUNT AIR CONDITIONERS

with Serial Numbers E18A1604 and above

DESCRIPTION

The **TrimLine Narrow-Mini Series** consists of compact models with a capacity of 2,500 BTU/H. This series is designed with a minimum width to take up less cabinet space on the exterior panel or door. In addition to being narrower than traditional Air Conditioner units, the **TrimLine Narrow-Mini Series** include the Condensate Evaporator and Programmable Thermostat as standard features, and are available in all popular voltages and frequencies.

Outdoor or corrosive environments require weather protection and/or special internal and external protective features. Also see Integrity NEMA 4/4X and Intrepid Outdoor Series.

For extreme ambient temperatures and/or severely contaminated environments, the use of **TrimLine** or other **Water-Cooled Air Conditioners** is recommended.

KOOLTRONIC also designs and manufactures a variety of Air Conditioners to meet *unique* specifications. We invite your inquiries about our modification and custom-design capabilities.

FEATURES AND BENEFITS (STANDARD)

All models UL/CUL Listed, a standard of safety.

Built-in condensate evaporator eliminates the need for a drain (normal operation*).

CFC-free refrigerant provides a zero ozone depletion potential.

Closed-loop cooling provides stable temperature control while excluding dust and humidity from the electrical enclosure.

Compressor short-cycling protection extends compressor life.

Condenser impeller cycling provides stable capacity and temperature control.

Condenser filtration to maintain peak thermal performance extends compressor life.

Evaporator coils are epoxy coated, prolonging unit life.

NEMA 12 rating for compatibility with listed electrical enclosures.

Programmable temperature alarm to alert if early action required.

Programmable thermostat capable of remote monitoring and control.

* May not be adequate in extremely high humidity with open or leaky enclosure. Overflow condensate drain fitting and hose are included.

FEATURES AND BENEFITS (OPTIONAL)*

Aluminum Shell if light weight and/or compatibility with aluminum enclosures is required.

High-Capacity Condensate Evaporator available if necessary.

Lead-lag control for two air conditioners provides for capacity control, and alternates usage, increasing reliability.

M-Tab Mounting for existing retrofits.

Mounting adapter plates are offered to replace another manufacturer's unit.

Remote monitoring provides temperature data for warning of early action required.

Remote thermostat relay for control by a user-supplied control system.

Stainless Steel Shell for applications in corrosive or other hostile environments.

Special paint finishes.

*Contact KOOLTRONIC for more information.

REPLACEMENT FILTERS

The Narrow-Mini filter Part No. is 8388F (8.13" x 8.38" x 0.34" [206.5mm x 212.8mm x 8.6mm])

