

THIS DOCUMENT IS THE PROPERTY OF KOOLTRONIC, INC. AND CONTAINS PROPRIETARY AND CONFIDENTIAL INFORMATION WHICH MUST NOT BE DUPLICATED, USED OR DISCLOSED TO OTHERS, EXCEPT AS EXPRESSLY AUTHORIZED IN WRITING BY KOOLTRONIC INC.

REVISIONS				
SYM	NOTICE	DESCRIPTION	DATE	APPROVED
-	ER 94/222	NEW DRAWING RELEASE	08/15/94	MJH
A	EC 95/43	REDIMENSIONED "M-TAB MOUNTING PLAN VIEW"	02/21/95	RDG

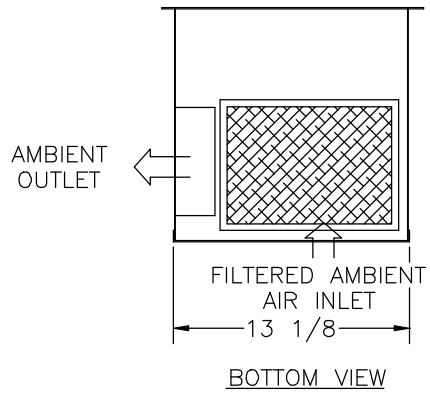
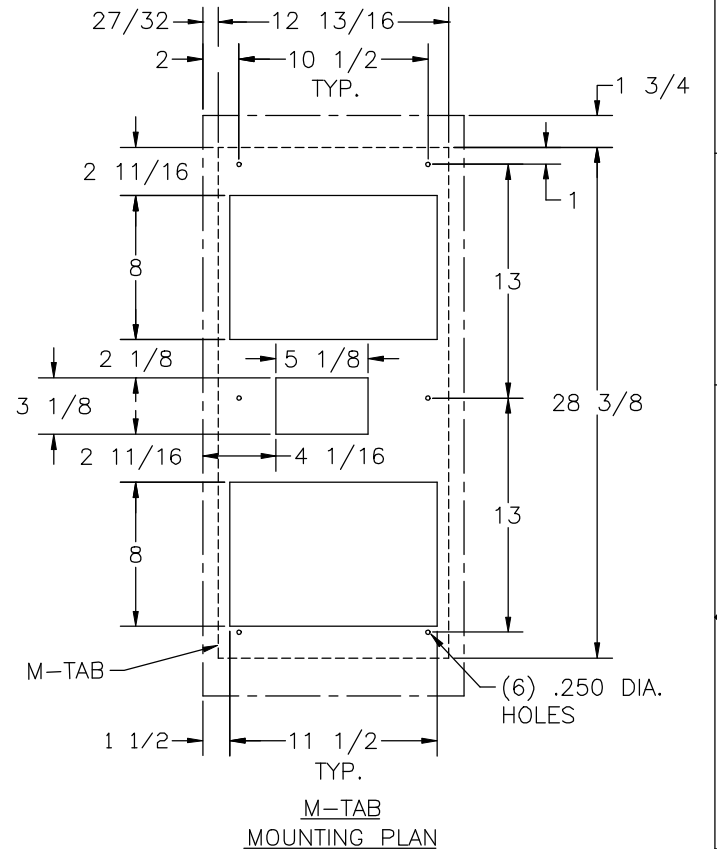
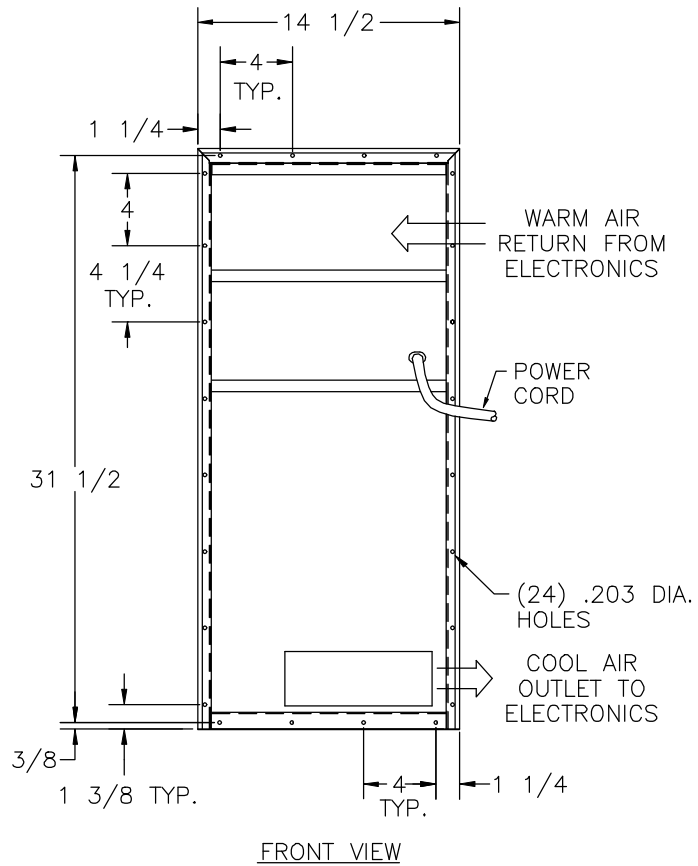
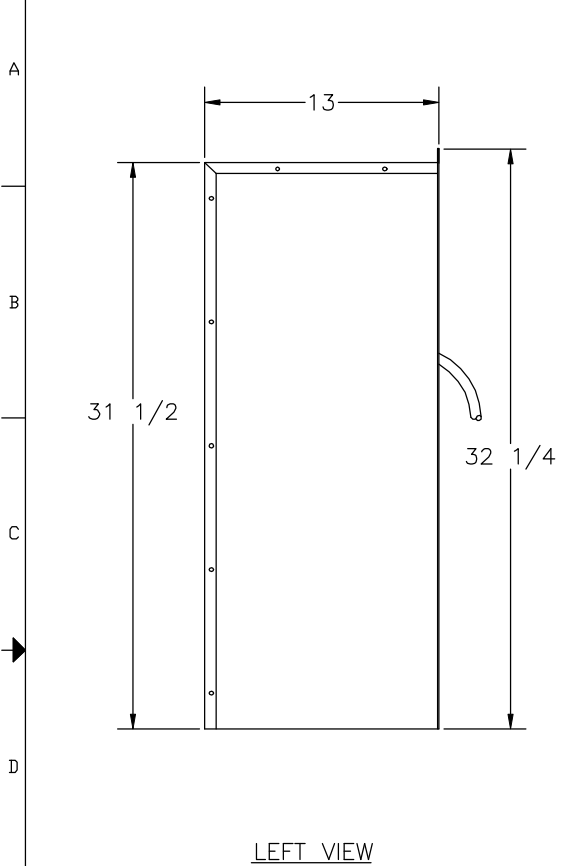

ALL DIMENSIONS ARE IN INCHES.  
DIMENSIONS DESIGNATED MM ARE IN MILLIMETERS.

UNLESS OTHERWISE SPECIFIED TOLERANCES NON-ACCUMULATIVE			DRAWN M. J. H. / B. C. S. / H. O. B.	DATE 08/15/94
TOL. ON	INCHES	MM	CHECKED	
.XX	± .02	±	ENG. B. MUZIKANT	12/07/94
.XXX	± .010	±	MFG. ENG.	
ANGULAR	± 1/2°			
MATERIAL				
UNIT KNHX32	APPROVED BKK/JC		12/12/94	

HOPEWELL, NJ. VENTURA, CA. USA

TITLE  
GENERAL ARRANGEMENT  
NEMA4 HEAT EXCHANGER

CODE IDENT. NO. 06223	SIZE C	DWG. NO. 604532-00-26	REV A
SCALE 0.187=1	CAD. REF. GA000144	SHEET 1 OF 1	