

KP60 FILTER BOX FANS

STANDARD FEATURES

- Exceptionally quiet
- Capacity: 220 CFM
- Versatile mounting and adaptability
- Rugged construction with baked powder finish
- UL/CSA ball bearing motors
- Attractive stainless steel grilles
- All models can pressurize or exhaust

ACCESSORIES AND OPTIONS

- Automatic Speed Control
- Brushless DC motors
- Filters
- Filter Recoating Adhesive
- Special internal paint finishes
- Special line cords or connectors



PERFORMANCE GRAPH

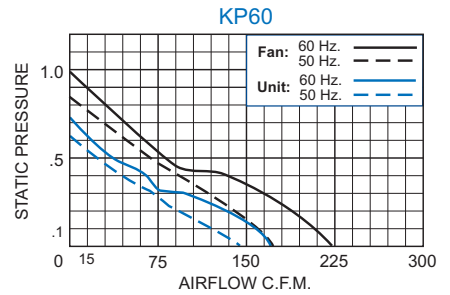

Airflow vs. static pressure curves are shown for 60 Hz and 50 Hz (broken line) inputs. Static pressure is in inches of water.

TECHNICAL DATA*

Model	Normally In Stock	Volts	CFM @ 0" S.P. Fan Only	RPM Nominal	Amps		Watts	Approx. Weight	
					Run.	L.R.		Lbs.	Kg.
KP60	Yes	115	220	3300	0.29	0.53	33	4	1.8
K2P60		230	220	3300	0.15	0.27	33	4	1.8

* 60 Hz. operation

DIMENSIONS inches [metric]

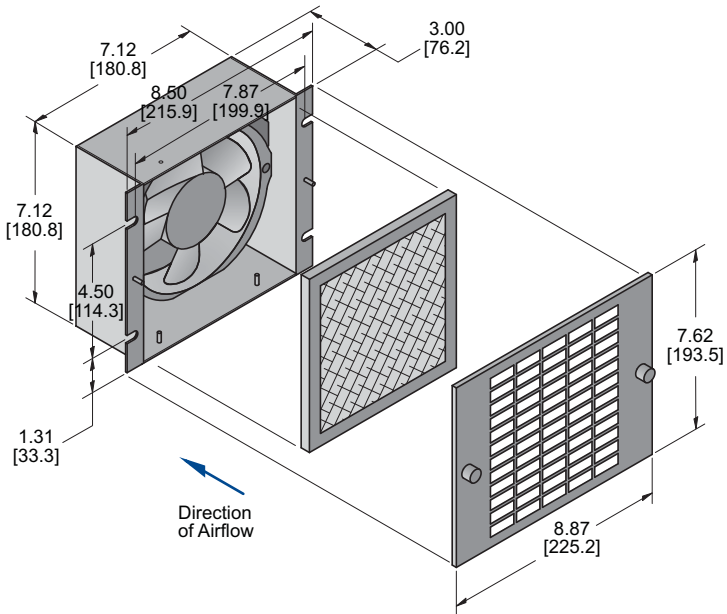

Filter-Grille Assembly KFG60

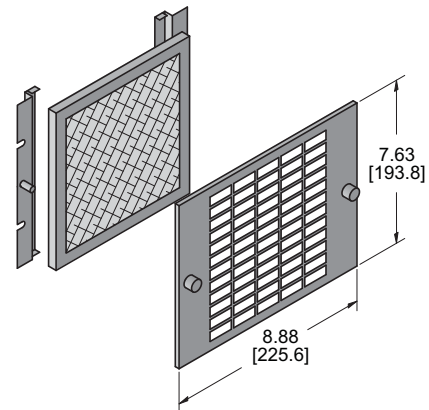

HOW TO ORDER

FANS: Specify model number. For 230 VAC operation, add a 2 after the K. Example: K2P60.

ACCESSORIES: Specify model number.

Dimensions, inches [mm], are for reference only and subject to change.

kp60.qxd 7/12/17

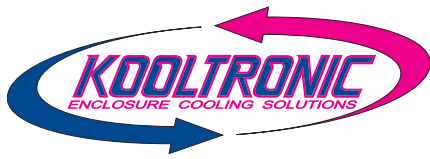

KP60 FILTER BOX FANS

DESCRIPTION

FILTER BOX FANS: High airflow with low noise operation makes these versatile packaged fans very popular in a wide range of applications, especially with their minimal internal cabinet depth requirement.

Reversible designs allow user to push or pull air through the enclosure. In addition, these fans can be installed internally or externally, vertically or horizontally, with or without a filter on either side. With the KOOLTRONIC special motor-mount isolation system, these fans operate virtually vibration-free. Front and rear grilles can be adjusted to accommodate or omit filter. Filters are easily removable for cleaning and replacement.

STANDARD FEATURES

RUGGED CONSTRUCTION: Precision-engineered heavy gauge steel construction insures fans stand up under tough applications.

BAKED POWDER FINISH: Durable, baked-on gray powder finish is standard. Other finishes are available.

BALL-BEARING MOTORS: All motors, whether permanent split capacitor or shaded pole, are UL/CSA Recognized and include automatic-reset thermal overload protection. Designed for low temperature rise, KOOLTRONIC motors are also cooled by fans' intake air, for maximum motor life. All motors meet Federal Specification CC-M-1807A, and include double-sealed or double-shielded precision ball bearings which meet Federal specification FF-B-171A. Special permanent lubricants perform over a broad temperature range: -20°F [-28.9°C] to 250°F [121.1°C].

POWER: 115 VAC or 230 VAC, 50/60 Hz is standard. For multiphase power, other voltages and frequencies or brushless DC applications, consult KOOLTRONIC.

LEADS: 12" [304.8mm] (minimum) power and ground leads without plugs.

ACCESSORIES AND OPTIONS*

AUTOMATIC SPEED CONTROL: The Kooltronic Fan and Blower Automatic Speed Control (Part Number KSC100) is a solid state "smart" controller packaged in a NEMA 1 type enclosure for remote mounting. The allowable input power supply range is 95 to 250 Volts, 47 to 63 Hz. It is furnished standard with an IEC 320 connector, a power supply fuse and a temperature sensor. Additional temperature sensors are optional.

The controller will operate single or multiple fans or blowers of compatible voltage and frequency up to a combined load of 6 Amps. The controller may be operated by either a control voltage signal of 0 to 10 VDC, a control current signal of 0 to 20 mA or one to three temperature sensors. With multiple temperature sensors the controller will respond to the highest sensed temperature.

The control circuit board is furnished with a terminal strip for field connecting the sensor and fan wires. A pressure type strain relief connector is furnished in the enclosure. If required by installation or by code, this connector can be replaced with a 1/2-inch [12.7mm] trade size conduit connector.

A wide variety of control logic options can be field programmed into the controller by means of a board mounted DIP switch. These include fan idle or starting speed at 30%, 40%, 50% or 60% of supply voltage, fan on or off below the idle setting, control temperature setting at 86°F (30°C), 95°F (35°C), 104°F (40°C), 113°F (45°C), and temperature differential settings of 7°F (4°C) and 18°F (10°C). The selectable fan on/off feature is operative when the temperature(s) drop below the control temperature setting.

Consult factory for use with compatible Kooltronic fans or blowers

FILTER RECOATING ADHESIVE: This compound is a superior product for recoating filters after washing. The adhesives penetrate dirt layers to keep the filter surface tacky for longer effective performance between washings. Part No. A-16 - 10 ounce container.

FILTERS FOR REPLACEMENT: All KOOLTRONIC filters consist of a multi-layer grid of sturdy corrugated aluminum, securely held in a one-piece aluminum frame. Filters are required wherever air is drawn into an electronics enclosure or related cooling equipment to keep internal parts as clean as possible. These filters are reusable, they may be washed and recoated with the appropriate filter recoating adhesive. Replacements are available for those which become damaged or otherwise non-serviceable.

BRUSHLESS DC MOTORS

SPECIAL EXTERNAL PAINT FINISHES

SPECIAL LINE CORD OR CONNECTORS

*Contact KOOLTRONIC for information.

ADDITIONAL SPECIFICATIONS

ENCLOSURES: Precision-engineered baked powder coated heavy-gauge steel construction.

GRILLES: Include a rear guard and an attractive stainless steel grille with knurled captive fasteners for easy removal. Grilles and guard comply with OSHA and UL safety standards.

FILTER: Furnished with each packaged fan. Recommended whenever air is drawn into the electronics cabinet. Filters consist of a multi-layer grid of sturdy corrugated aluminum in a one-piece aluminum frame. Adhesive coated to trap particulate matter, they are easy to remove, wash and treat with KOOLTRONIC A-16, an adhesive rejuvenating spray. Filters must be kept free of accumulations, to prevent reduction or loss of performance and/or damage to equipment.

KOOLTRONIC also designs and manufactures a variety of Fans to meet *unique* specifications. We invite your inquiries about our modification and custom-design capabilities.