

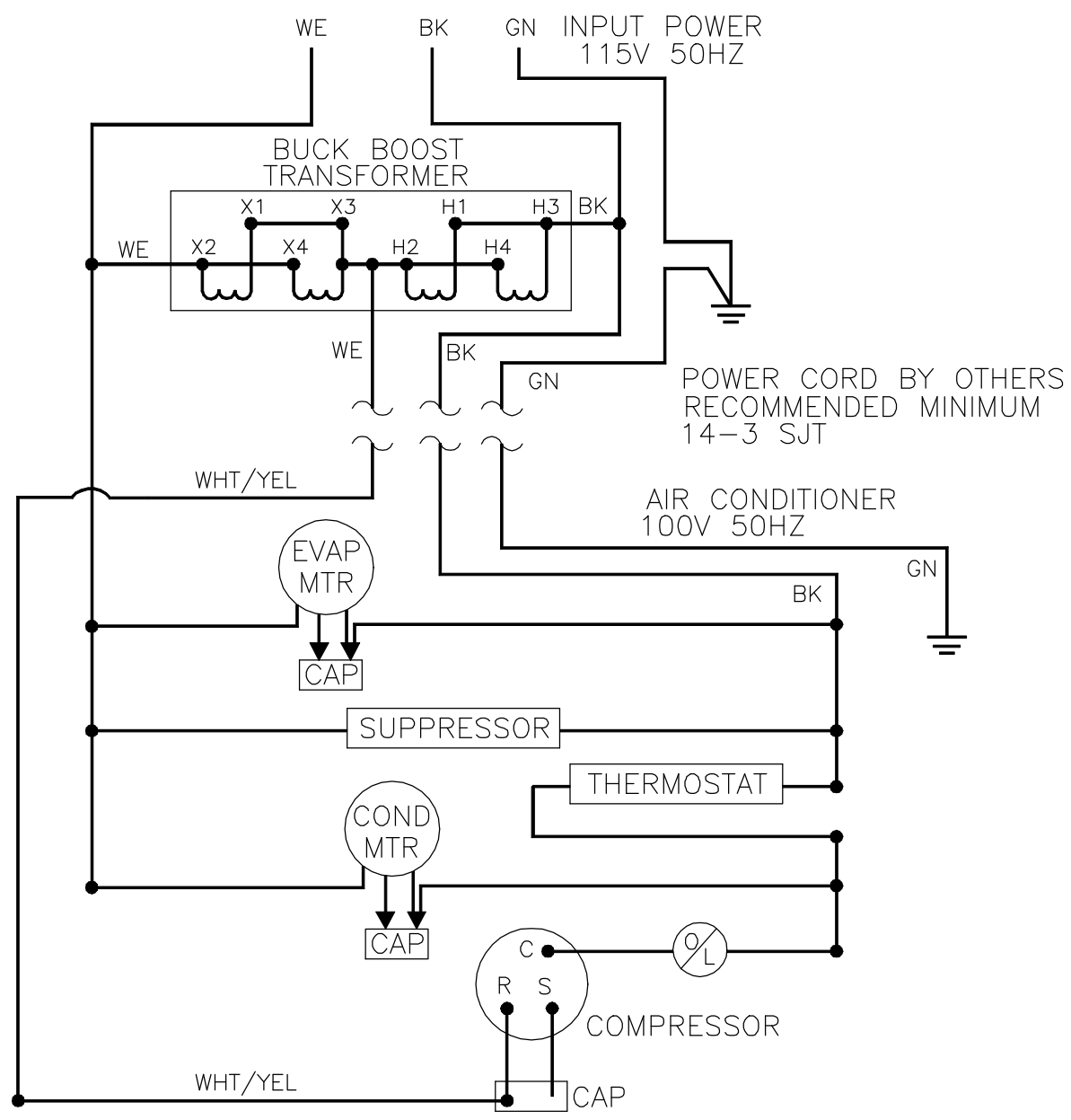

THIS DOCUMENT IS THE PROPERTY OF KOOLTRONIC, INC. AND CONTAINS PROPRIETARY AND CONFIDENTIAL INFORMATION WHICH MUST NOT BE DUPLICATED, USED OR DISCLOSED OTHER THAN AS EXPRESSLY AUTHORIZED BY KOOLTRONIC, INC.

REVISIONS				
SYM	NOTICE	DESCRIPTION	DATE	APPROVED
-	ER 92/259	NEW DRAWING RELEASE	12/04/92	MJH
A	EC 93/54	REVISED WIRING FROM TRANS. TO COMPRESSOR	4/7/93	MJH
B	EC 97/3	H1 WAS H2, H2 WAS H1, H3 WAS H4, H4 WAS H3 X1 WAS X2, X2 WAS X1, X3 WAS X4, X4 WAS X3	1/3/97	JMB



ALL DIMENSIONS ARE IN INCHES, DIMENSIONS DESIGNATED MM ARE IN MILLIMETERS.				
UNLESS OTHERWISE SPECIFIED TOLERANCES NON-ACCUMULATIVE			DRAWN <i>MARTIN H IRCSHHORN</i>	DATE 12/4/92
TOL. ON	INCHES	MM	CHECKED BF	4/16/93
.XX	± .02	±	ENG. JC	4/16/93
.XXX	± .010	±	MFG. ENG.	
ANGULAR		± 1/2°		
MATERIAL				
UNITS KAC3NP33/50-1			APPROVED	



KOOLTRONIC, INC.
HOPEWELL, NJ VENTURA, CA USA

WIRING DIAGRAM

CODE IDENT. NO. 06223	SIZE A	DWG. NO. WD-134	REV B
SCALE 1.000=1	CAD. REF. WD000022	SHEET 1 OF 1	