

REVISIONS				
SYM	NOTICE	DESCRIPTION	DATE	APPROVED
-	ER 93/191	NEW DRAWING RELEASE	9/20/93	D W
A	EC 96/250	REV. NUMBERS, H1-H4, X1-X4	11/11/96	SDS

## TRANSFORMER HSG.

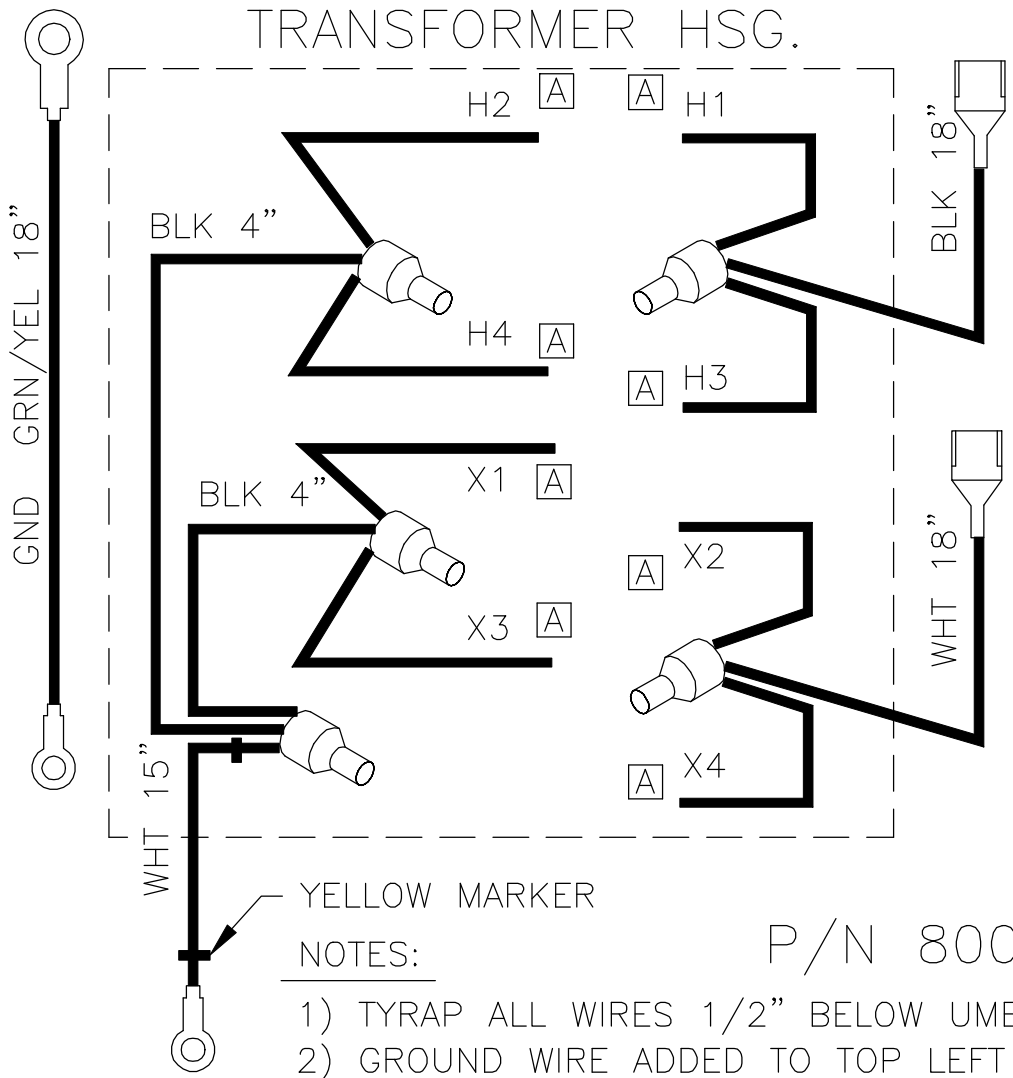

YELLOW MARKER

**NOTES:**

- 1) TYRAP ALL WIRES 1/2" BELOW UMBRELLAS.
- 2) GROUND WIRE ADDED TO TOP LEFT TRANSF. MTG. SCREW ON FINAL ASSY.
- 3) ALL WIRES TO EXIT TRANSFORMER THRU GROMMET.
- 4) REMOVE CAP. JUMPER WIRE ON FINAL ASSY.
- 5) REMOVE COMP. WHT WIRE FROM TERMINAL BLOCK. ATTACH REPLACEMENT WIRE TO CAP.

P/N 8007-0T-04

THIS DOCUMENT IS THE PROPERTY OF KOOLTRONIC, INC. AND CONTAINS PROPRIETARY AND CONFIDENTIAL INFORMATION WHICH MUST NOT BE DUPLICATED, USED OR DISCLOSED OTHER THAN AS EXPRESSLY AUTHORIZED BY KOOLTRONIC, INC.

ALL DIMENSIONS ARE IN INCHES, DIMENSIONS DESIGNATED MM ARE IN MILLIMETERS.			
UNLESS OTHERWISE SPECIFIED TOLERANCES NON-ACCUMULATIVE		DRAWN D. WALDRON	DATE 9/20/93
TOL. ON	INCHES	MM	CHECKED
.XX	± .02	±	ENG.
.XXX	± .010	±	MFG. ENG.
ANGULAR		± 1/2°	
MATERIAL			APPROVED
UNITS KAC2.5NM/56			



**KOOLTRONIC, INC.**  
HOPEWELL, NJ VENTURA, CA USA

WIRING DIAGRAM  
TRANSFORMER 115V

CODE IDENT. NO. 06223	SIZE A	DWG. NO. WD-161	REV A
SCALE 1=1	CAD. REF. WD000051	SHEET 1 OF 1	