



**INTEGRITY SERIES
K_NA4C4P32L
KNA6C4P32L**

**Keep This Manual
With Air Conditioner**

Find additional information on this model at kooltronic.com, or use the Technical Documents QR code below.

Technical Documents

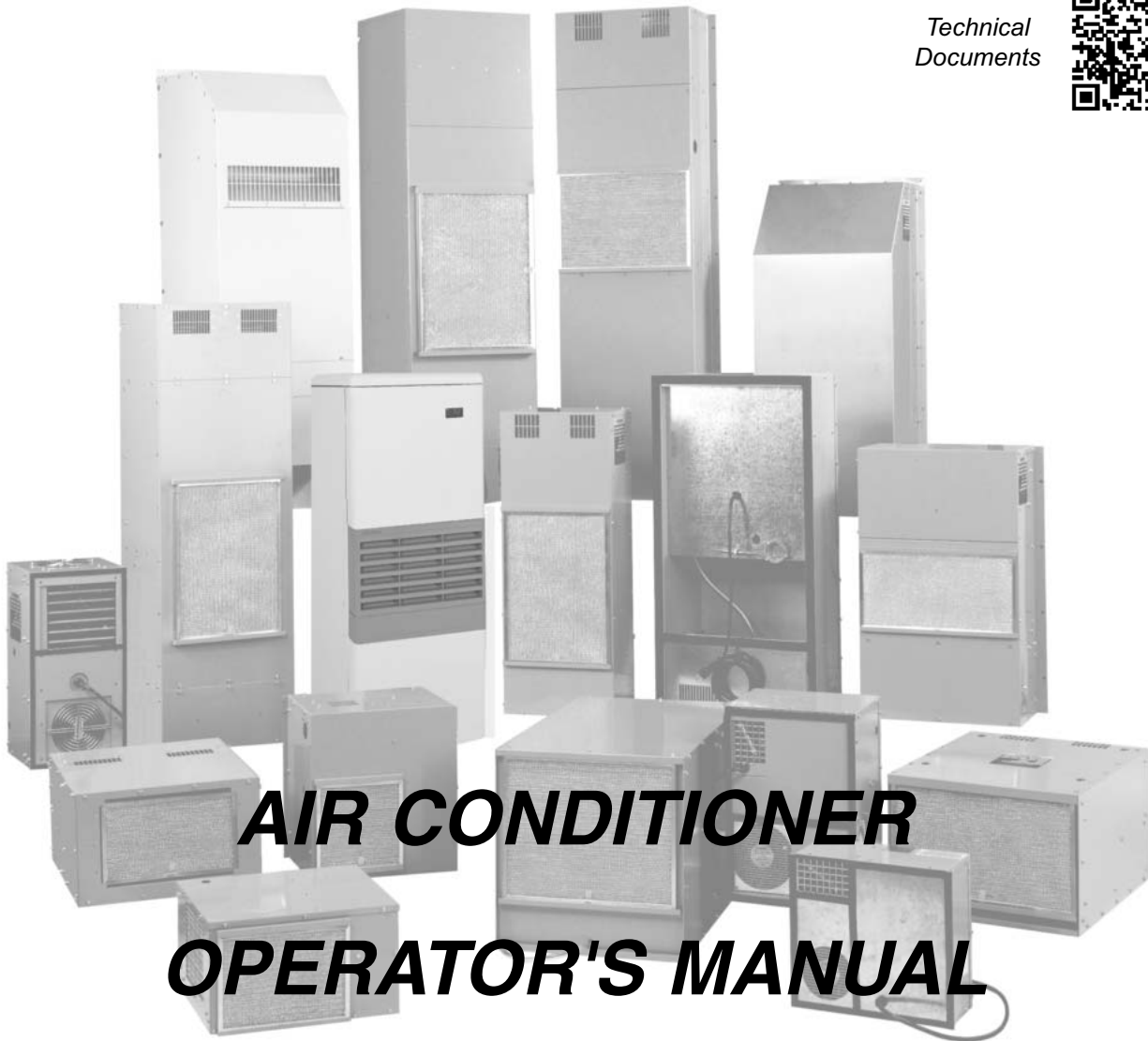

AIR CONDITIONER OPERATOR'S MANUAL

CAUTION

BEFORE INSTALLING AND USING THIS AIR CONDITIONER, IT IS IMPORTANT THAT THIS MANUAL BE READ AND UNDERSTOOD THOROUGHLY



KOOLTRONIC, INC.
30 Pennington-Hopewell Road
Pennington, NJ 08534
609•466-3400
FAX: 609•466-1114
www.kooltronic.com

TABLE OF CONTENTS

		Page
I.	Introduction	2
II.	Incoming Inspection	3
III.	Product Handling	3
IV.	Product Identification and Nameplate	4
V.	Principles of Operation	5 - 6
VI.	Pre-Installation Testing	6
VII.	Specific Model Data	7 - 9
	Mounting	
	Drawings and Dimensions	
	Technical Data	
	Major Component Replacements	
	Standard Features	
VIII.	Maintenance	10 - 11
IX.	Trouble Shooting	12
X.	Warranty	13

NOTE: Wiring Schematics are available on the specific model page of the Kooltronic website.

I. Introduction

Kooltronic Air Conditioners are designed to provide a cool, dehumidified environment for your electronic components. There are models to fit virtually all sizes and shapes of electronics enclosures, in capacities ranging from 1,000 to 30,000 BTU/H. Our "closed-loop" design also ensures that your components will not be exposed to hot, dirty operating conditions.

This Manual provides you with the necessary general information for properly installing and operating standard Kooltronic Air Conditioners. Technical data and mounting instructions are presented on pages 7 through 9.

II. Incoming Inspection

Kooltronic Air Conditioners are designed, built and packaged to withstand the shock and vibration normally associated with shipment by common carriers. Occasionally improper handling during shipping causes damage. Such handling could include unbanding of palletized shipments, failing to respect "**This Side Up**" arrows, rough handling, falling off conveyors, excessive vibration, crushing, etc. Therefore, a thorough inspection should be done upon receipt of all shipments. Any carton tears, dents, scratches, loose articles or evidence of oil are signs of damage and should be noted on the Freight Bill. Cartons should be opened promptly and the units inspected for CONCEALED DAMAGE. Kooltronic Air Conditioners must be delivered in the proper mounting position to assure that damage to the compressor has not occurred during shipping. Any Kooltronic Air Conditioner that is delivered removed from the banded pallet, lying down or double stacked should be refused.

An immediate claim **MUST** be filed with the freight carrier and an inspection requested. Retain all packing materials. Kooltronic cannot assume responsibility for Consignee's failure to file a timely freight claim.

III. Product Handling:

- 1) Do not attempt to operate your Kooltronic Air Conditioner until you read and thoroughly understand this Manual. See section **VI PRE-INSTALLATION TESTING**.
- 2) Before operating the Kooltronic Air Conditioner be certain that it is placed in its correct mounting position. **This Air Conditioners is designed to operate in a vertical position only.** This placement must be done a minimum of 5 minutes prior to operating in order to allow the compressor oil to drain to the compressor sump area.

CAUTION

Kooltronic Air Conditioners must be operated in their proper mounting position. If attempts are made to operate a unit that is not in its designed mounting position, permanent compressor damage will occur. This action will void the warranty. To avoid compressor damage do not tip the unit more than 45° from its proper mounting position.



- 3) Before operating this unit, all electrical wiring must be checked to assure the proper connection to the correct power source. Minimum circuit ampacity should be at least 125% of the amperage found on the nameplate for the corresponding voltage. Do not exceed the maximum fuse size found on the nameplate.
- 4) We do not recommend that Air Conditioners be shipped to their final destination attached to an enclosure. In the event that the Air Conditioner needs to be shipped attached to an enclosure it is strongly recommended that proper support be provided for the Air Conditioner. Excessive vibration can occur if Air Conditioners are not properly supported when shipped on enclosures, increasing the potential for internal damage and voiding the warranty.
- 5) **PROCEDURE FOR PROPER PACKING AND SHIPMENT OF KOOLTRONIC AIR CONDITIONERS:**
 - Keep Air Conditioner in proper upright position indicated by arrow markers.
 - Pack Air Conditioner in an appropriate carton (preferably original carton if possible), with adequate internal protective packaging, making sure carton is marked and is kept in correct upright position.
 - For local, controlled transportation, strap carton to a secure part of truck to prevent falling or sliding, minimize vibration, etc.
 - For common carrier shipment, band unit(s) securely to a pallet. Unpalletted shipment risks severe damage which voids the warranty.

IV. Product Identification and Nameplate

Each Kooltronic Air Conditioner includes an identification nameplate. This nameplate provides:

- ① Model Number
- ② Serial Number
- ③ Electrical power characteristics
- ④ Maximum and minimum ambient operating temperatures
- ⑤ Cooling capacity
- ⑥ Type and amount of refrigerant required for recharging
- ⑦ Design Pressure
- ⑧ Maximum Fuse Size
- ⑨ Manufacturing Order Number
- ⑩ Filter Part Number
- ⑪ Underwriters Laboratories Inc. Listed or Recognized Marks and NEMA ratings

We recommend you copy this information from your unit.

		Air Conditioner			
		MODEL NUMBER		SERIAL NUMBER	
①		②			
VOLTS	FREQ.	PH.	COOLING F.L.A.	AMBIENT TEMP. MIN. °F	MAX. °F
③	③	③	③	④	④
COOLING BTU		REFRIGERANT		Oz.	
⑤		⑥			
DESIGN PRESSURE P.S.I.G.		MAX. FUSE SIZE		FILTER P/N	
LOW	HIGH	⑧		⑩	
⑦	⑦	MFG. ORDER NO.			
		⑨			
					
				⑪	
<p>SPECIAL PURPOSE AIR CONDITIONER NEMA/VEEMAC/UL50 BY UNDERWRITERS LABORATORIES, INC. TYPE 4/4X INTERFACE TO THE ELECTRICAL ENCLOSURE ONLY NEMA/VEEMAC/UL50 BY UNDERWRITERS LABORATORIES, INC. TYPE 3R SPECIAL PURPOSE AIR CONDITIONER EQUIPMENT COMPARTMENT ONLY OUTDOOR USE SERVICE AIR FILTER REGULARLY ALLOW 5 MIN. BEFORE RESTARTING AFTER SHUTDOWN UNAUTHORIZED SERVICE OR MODIFICATION VIOLATES WARRANTY ALL MOTORS ARE THERMALLY PROTECTED</p>					
<p>MANUFACTURED BY: KOOLTRONIC, INC. PENNINGTON, NJ</p>					
					

①②⑨ When ordering parts, specify the Model Number, Serial Number & MFG. Order Number.

③ Before operating, be sure that the power source matches these requirements.

④ Make sure that these parameters are met. Failure to do so may result in permanent damage to the unit.

⑥ Use of incorrect type or amount of refrigerant will adversely affect performance and may damage the unit.

V. Principles of Operation

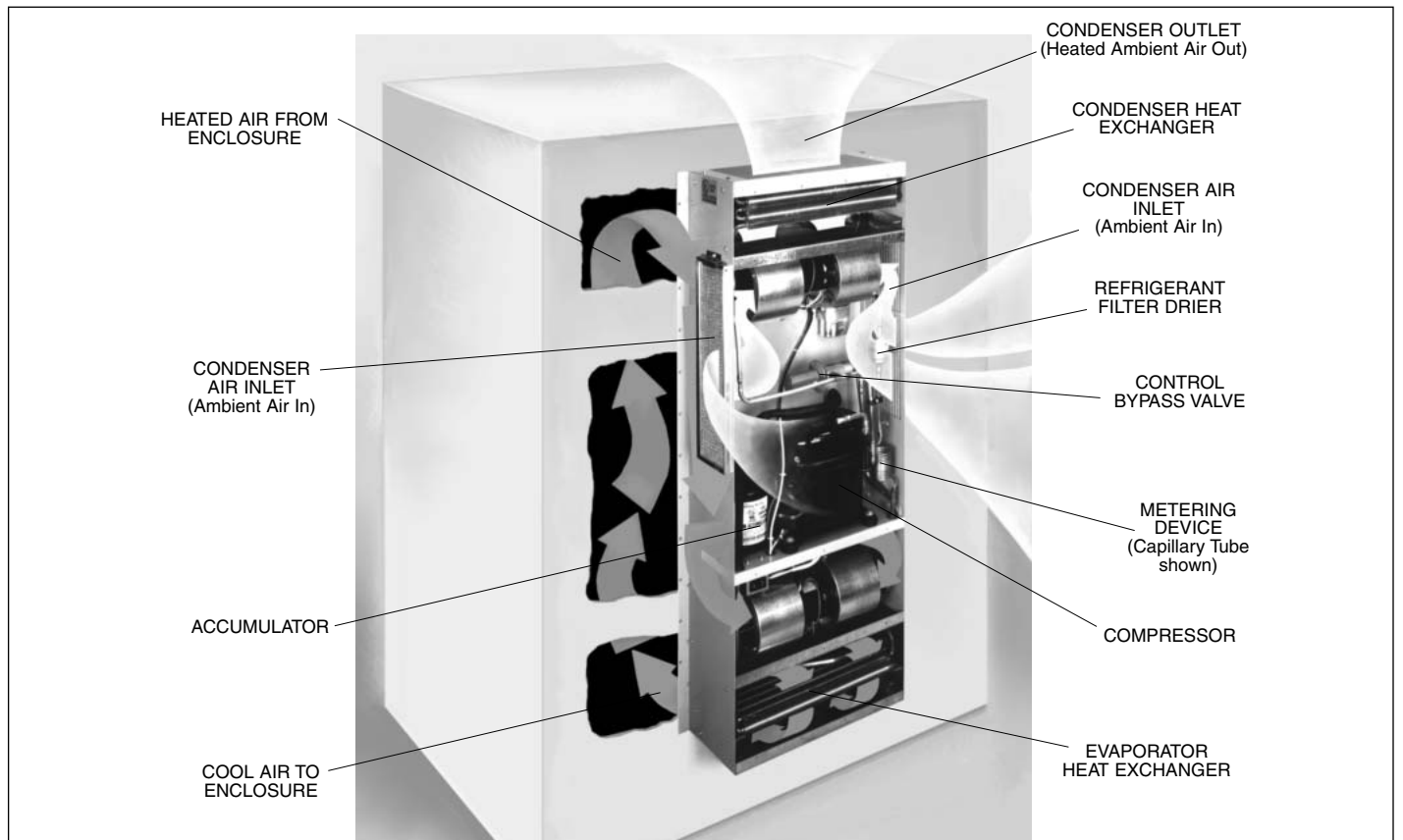

Kooltronic Air Conditioners are required when the equipment operating temperature must be kept near or lower than the ambient room temperature, and/or the cabinet must be sealed from dust, fumes, oil, corrosives and other contaminants. This Air Conditioner utilizes a "Closed-Loop Cooling System" to ensure optimum performance of the installed components.

Closed-Loop cooling seals the electrical enclosure from hostile elements in the environment. Two separate circulation systems are employed. The internal system cools and dehumidifies the air inside the cabinet, totally isolating the sensitive electronics and other components from the environment. The external system uses circulating ambient air or water to discharge the heat removed from the electronics. The heat is dissipated from the enclosure by means of the vapor compression refrigeration cycle. This takes place in a hermetically-sealed refrigeration system, utilizing either an air-cooled or water-cooled condenser heat exchanger. The warm air inside the enclosure is drawn through the evaporator coil where it is cooled, dehumidified and returned.

Any enclosure moisture accumulated on the evaporator coil is collected in the condensate tray and released to the ambient air through the drain tube or the condensate evaporator.

The heat removed through the evaporator coil is transferred by the compressed refrigerant to the condenser coil. Ambient air or water is then passed through the condenser coil, where it absorbs the heat and is then discharged to the environment.

The cool air discharge temperature is regulated by the capacity control (hot gas bypass) valve. The unit is equipped with a Low Temperature Thermostat to prevent over-cooling. In applications having frequent voluntary heat load fluctuations, an optional Compressor Short Cycle Protector is recommended.

VI. Pre-Installation Testing

Before mounting the air conditioner to the enclosure, test for proper operation. This will verify the shipping integrity of the system. Please follow the steps below prior to installation.

CAUTION

The Air Conditioner must be standing in its proper mounting position for a minimum of five (5) minutes prior to testing. Failure to follow this procedure will cause permanent damage to the compressor.

1. Allow the unit to sit in an upright position at a room temperature of 65°F minimum, allowing the system to warm-up. This is particularly important in winter months.
2. Refer to the nameplate for proper electrical voltage and current requirements. Then connect the power cord to a properly grounded and fused electrical supply. Leave the electrical power off.
3. Note the factory thermostat setting which is typically 75 to 80°F.
4. Adjust thermostat to its maximum setting.
5. If your unit is equipped with an on-off switch, move it to the on position.
6. Turn electrical power on.
7. Verify that the evaporator blower or fan is running.
8. Adjust the thermostat to its minimum setting. The compressor should start. On units equipped with a short cycle protector, the compressor will have a delayed start of 6 minutes from the time power is applied to the unit.
9. Verify that the condenser blower or fan is running. Note, on units equipped with a low ambient kit, the start of the condenser fan or blower will be delayed until the system pressures rise.
10. Operate the air conditioner for approximately ten minutes. During this period no unusual noise or vibration should be evident. Both the evaporator and condenser fans or blowers should be delivering air through their respective discharge ports. The cool air discharged should be less than 70°F when the room temperature is between 70 and 80°F.
11. On units equipped with heaters, adjust both the cooling and heating thermostats to their maximum settings. Verify that the compressor and condenser fan or blower has stopped. Verify elevated discharge air temperature from the evaporator air discharge.
12. If your unit is equipped with an on-off switch, leave it in the on position. Return the cooling thermostat to its original setting. If unit is equipped with a heater, return the heating thermostat to its original position.
13. Turn off the electrical power source, and disconnect the air conditioner from the power source.
14. If any cover plug is removed to adjust the unit, make certain to put back in place to maintain the integrity of the closed-loop airflow system.

NOTE: Before shipment all Kooltronic, Inc. Air Conditioners are subjected to a performance test.

VII. Specific Model Data

Mounting

Kooltronic Special Purpose Air Conditioners K_NA_C4P32 have been engineered to be installed easily. These units use fully gasketed flanges to insure a seal between the air conditioner and the cabinet. This seal is necessary to maintain the integrity of the closed loop system as well as the NEMA 4 rating.

Prior to mounting, refer to page 8 for general arrangement drawings showing dimensions and locations of mounting holes and cutouts. Prior to cutting or drilling, make sure that cutouts and mounting holes do not interfere with components inside of the cabinet. To avoid damaging your Air Conditioner, please read the following information before installation.

1. Remove and discard (2) nuts and washers holding the Mounting Template and Assembly Bracket (M/TAB) to the Air Conditioner. Remove M/TAB.
2. See page 8 for proper orientation. Place the M/TAB flush against the outside of the cabinet to locate cutouts and M/TAB mounting holes. **The minimum distance between lower end of the M/TAB to the ground is 11" for all P32 units.**
3. The cutout for warm air return does not have to match the full 8" x 11 $\frac{1}{2}$ " opening on the M/TAB. You can locate your cutout anywhere within this opening, making the return air cutout from the cabinet as large as possible. Make the cold air supply cutout the same size as on the M/TAB.
4. Mount the M/TAB to the outside of the cabinet using all the 1/4-20 x 1/2" bolts, washers and nuts supplied by Kooltronic.
5. Route the power cord through the return air cutout of the cabinet. Mount the air conditioner on the M/TAB by sliding the (4) mounting studs, installed on the air conditioner side panels, into the (4) inclined slots of the M/TAB.
6. Carefully mark all mounting holes from the flanges of the air conditioner to the cabinet wall. All holes in the air conditioner flange must be used to maintain the NEMA 4 rating.
7. Remove the air conditioner from the M/TAB and drill .218" dia. mounting holes in the cabinet. Do not attempt to drill mounting holes in the enclosure without first removing the air conditioner. Drilling through the sealing gasket may damage it and remove the NEMA 4 rating.
8. Repeat actions, described in item "5" above.
9. Insert the stainless steel screws with seal washers supplied through holes in the mounting flanges and the cabinet wall. Install washers and nuts on each screw from inside of the cabinet and hand tighten. Tighten all nuts to a torque of 20 in.-lbs. going in a clockwise rotation starting from the top left corner. Retighten to a final torque of 34-40 in.-lbs. in the same rotation as previously used. The torque should be rechecked after the gasket has been allowed to set for 1 hr. and again after the air conditioner has been run for 24 hrs. Check the flange gasket compression, after tightening all nuts - the gasket should be compressed by approximately 1/2 the gasket thickness (1/8").
10. After making sure that the source voltage and frequency are the same as shown on the unit nameplate, connect the air conditioner's power cord to the power supply.

CAUTION

If the Air Conditioner is mounted to the cabinet door you must be sure that the door hinges will support the additional weight of the Air Conditioner. Also be certain that when the door is opened fully, the cabinet does not become unbalanced. The actual weight of the unit can be found in the performance specifications.

Drawings and Dimensions

INTEGRITY SERIES K_NA4C4P32L K_NA6C4P32L

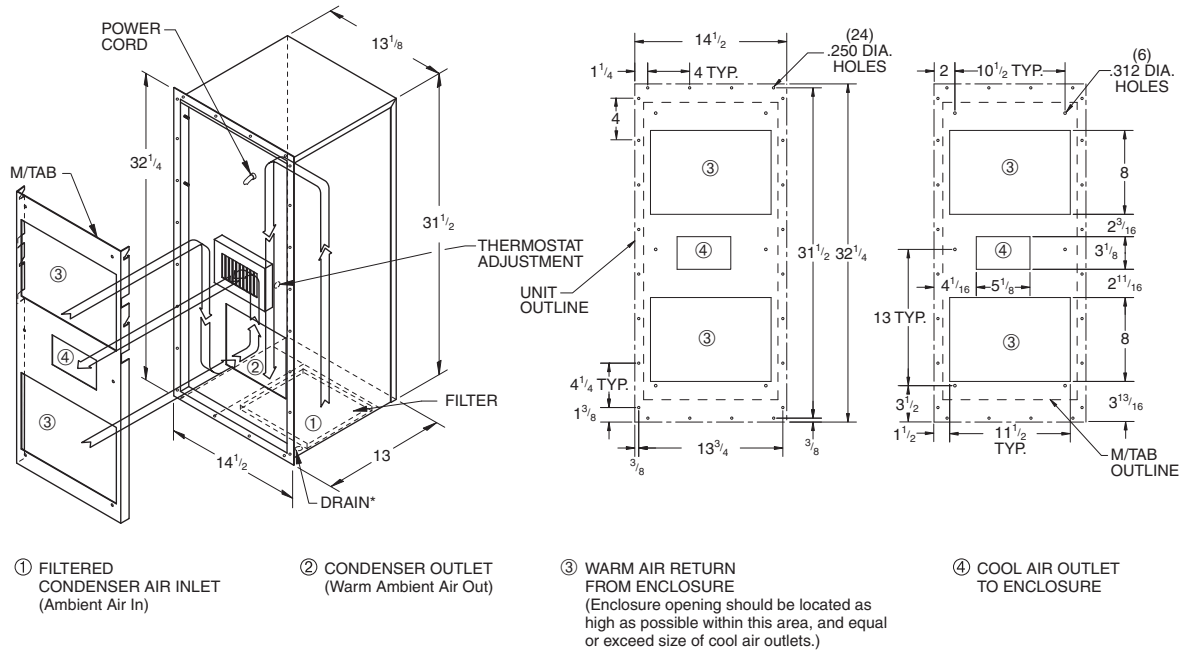

* Other drain outlets are available - consult KOOLTRONIC.
Dimensions (inches) are for reference only and are subject to change.

Technical Data

Model	** BTU/H Rating	Ambient Temp. °F Max./Min.	◇ Volts	◇ Hz	** Running Amps	Approximate Weight (lbs.)
KNA4C1P32R	1000	125/0	115/100	60/50	13.0/12.0	105
KNA4C1P32R56	1000	125/0	115	50/60*	13.0	105
K2NA4CP32R	1000	120/0	230/200	60/50	6.0	105
K2NA4C1P32R5	1000	125/0	230	50	6.5	105
KNA4C2P32R	2000	125/0	115/100	60/50	13.0/12.0	105
KNA4C2P32R56	2000	125/0	115	50/60*	13.0	105
K2NA4C2P32R	2000	120/0	230/200	60/50	6.0	105
K2NA4C2P32R5	2000	125/0	230	50	6.5	105
KNA4C3P32R	3000	125/0	115/100	60/50	13.0/12.0	105
KNA4C3P32R56	3000	125/0	115	50/60*	13.0	105
K2NA4C3P32R	3000	120/0	230/200	60/50	6.0	105
K2NA4C3P32R5	3000	125/0	230	50	6.5	105
KNA4C4P32L	4000	125/0	115/100	60/50	13.0/12.0	105
KNA4C4P32L56	4000	125/0	115	50/60*	13.0	105
K2NA4C4P32L	4000	120/0	230/200	60/50	6.0	105
K2NA4C4P32L5	4000	125/0	230	50	6.5	105
KNA6C4P32L	4000	125/0	115	60	8.8	105

* Switchable. Switch is internally-mounted for security.

** Rating shown is for operation at maximum ambient temperature.

◇ 115V, 60 Hz and 230V, 60 Hz models also perform at full capacity when operated at 100V, 50 Hz or 200V, 50 Hz respectively. No transformer is required.

Units in BOLD are current standard products. Other units are prior product offerings and shown for reference only.

Major Component Replacements

Part	KNA4C4P32R Part Number	K2NA4C4P32R Part Number	K2NA4C4P32L Part Number	KNA6C4P32L Part Number
Compressor	0665-101	0665-107	0665-110	0665-414
Compressor Capacitor	N/A	0452-51	0452-51	0452-54
Condenser Blower Motor	0261-102	0261-84	0261-84	0261-102
Condenser Blower Motor Capacitor	0452-05	0452-05	0452-05	0452-05
Condenser Blower Assembly	5940-01-02	5940-02-02	5940-02-02	5940-01-02
Evaporator Blower Motor	0261-120	0261-121	0261-121	0261-120
Evaporator Blower Motor Capacitor	0452-06	0452-03	0452-03	0452-06
Evaporator Blower Assembly	604532-00-25	604532-00-55	604532-00-55	604532-00-25
Filter (1 each)	650F & 8751F	650F & 8751F	650F & 8751F	650F & 8751F

NOTE: Part Numbers shown are for 60Hz/1Ø. For 50Hz consult Kooltronic.

Standard Features

CFC-Free Refrigerant
Closed-Loop Cooling
Head Pressure Control Switch
Internal Corrosion Protection
Low Temperature Control Thermostat
NEMA 4/4X Rating Maintained (UL50)
Stainless Steel (304-2B) Cabinet
UL/CUL Listed

Filter Removal and Service

All NEMA 4 Air Conditioners are equipped with bottom filters. P32 Series units are equipped with an additional rear filter.

1. To replace the bottom filter simply push the filter toward the front using the rear filter attached tab. Push the filter toward the front and downward until the rear part of the filter clears the rear filter retainer.
2. To replace the rear filter in the P32 series lift the filter using both sides of the lower filter frame with both hands. Push the filter toward you and upward until the bottom of the filter clears the lower filter retainer.
3. After removal, the filters should be flushed under warm running water with the clean side up, driving contaminants out the dirty side of the filter. If the accumulated dirt is oily, washing in a detergent bath is recommended, followed by a warm water rinse as above.
4. The filters may be sprayed with Kooltronic A-16 Filter Recoating Adhesive to trap fine airborne contaminants, or they may simply be dried and reinstalled as strainer type filters. Recoating is recommended for best results.
5. Reinstall the bottom filter:
 - a) keeping the tab at the rear (bottom) slide filter into the front retainer,
 - b) press filter upward and
 - c) slide back into rear retainer
6. Reinstall the rear filter:
 - a) keeping filter at the frame sides slide it in the space between the outer rear/top cover and internal rear panel from the bottom toward the top,
 - b) reaching the upper retainer, slide filter into upper retainer,
 - c) press filter against the unit and
 - d) slide down into lower retainer

VIII. Maintenance

Kooltronic Water-Cooled Air Conditioners require no maintenance. Air-Cooled Air Conditioners are designed to require only the routine cleaning of air filters to assure unimpeded airflow through the condenser heat exchanger. It is not possible to recommend specific filter cleaning intervals since the level and the nature of airborne particulate matter differs widely with each installation. It is generally sufficient to remove and wash the reusable aluminum mesh air filters when the outer surfaces of these filters appear covered with a thin layer of dust or lint. Filter recoating adhesive is recommended. Appropriate disposable filters are available from Kooltronic.

If filter service is neglected or delayed, the air conditioner will not perform at its design capacity. The first indication of excessively clogged air filters is usually a gradual increase of temperature within the equipment cabinet. If operation is continued under these conditions, the compressor will be shut off by the thermal overload device. The compressor will restart when its external temperature drops below the protector threshold setting and the compressor will continue to cycle on and off. Continued operation under these conditions will cause damage, shorten compressor life and void the warranty.

A. Filter Removal and Service

Kooltronic Air Conditioners feature an easily removable inlet filter to facilitate necessary cleaning.

CAUTION

Do not operate the air conditioner for extended periods of time with the filter removed, as the condenser coil may become clogged with dust or lint from the air entering the face. A unit with a clogged condenser coil will have the same reaction as one with a clogged filter. A clean filter is the best protection.

- 1) Lift the filter, using the attached tab, to clear the lower filter retainer. Pull filter toward you and downward until the top of the filter clears the upper filter retainer.
- 2) After removal, the filters should be flushed under warm running water with the clean side up, driving contaminants out of the dirty side of the filter. If the accumulated dirt is oily, washing in a detergent bath is recommended, followed by a warm water rinse as above.
- 3) The filters may be sprayed with **Kooltronic A-16 Filter Coating Adhesive** to trap fine airborne contaminants, or it may simply be dried and reinstalled. **Recoating is recommended for the best results.**
- 4) Reinstall the filter: (a) keeping the tab at the bottom, slide filter into the upper retainer, (b) press filter against the unit and (c) slide down into lower retainer

B. Blowers

The design life of the blowers used in all Kooltronic Air Conditioners is substantially in excess of 20,000 hours. All Kooltronic condenser and evaporator blowers are equipped with automatic-reset thermal overload protectors.

CAUTION

Before opening the air conditioner, disconnect all power.

If field replacement of a blower motor is necessary, most blower assemblies, including the mounting plate, are readily removable. Each of the blower mounting plates is held to the air conditioner cabinet structure by screws and nuts. For installation of the replacement blower, electrical connections may be broken at the terminal block, or power leads may be cut and appropriately spliced together.

C. Compressor

All Kooltronic compressors are approved by UL and CSA, and require no maintenance. They are hermetically sealed and charged at the factory, and equipped with automatic-reset thermal overload protectors.

If the compressor or the hot gas bypass valve fails, it is strongly recommended that the air conditioner be returned to Kooltronic for service.

D. Refrigerant Loss

Kooltronic Air Conditioners are subjected to a series of tests to detect refrigerant leaks, during and after manufacture. It is possible that shipping or other damage, or microscopic leaks over a long period, may result in the need for replenishment of refrigerant charge. **When it has been verified by a Certified EPA Technician that a refrigerant shortage does exist, the leak must be repaired. Then the unit may be evacuated and recharged in the field by a Certified EPA Technician only.**

CAUTION

Refer to the data on the unit nameplate which specifies the type of refrigerant and the amount of charge in ounces.

E. Relocation

If your Kooltronic Air Conditioner has to be moved to another location by truck, the following precautions should be taken:

- De-mount the air conditioner from the equipment, controller or enclosure.
- Conform to the applicable provisions of PROCEDURE FOR PROPER PACKING AND SHIPMENT OF KOOLTRONIC AIR CONDITIONERS in this manual under *Section III. "PRODUCT HANDLING."*

IX. Trouble-Shooting

Each Kooltronic Air Conditioner is engineered for performance and built for reliability. They are designed to require no routine maintenance other than the cleaning of ambient air filters. If your air conditioner should require warranty service, please contact Kooltronic. If you require service out of warranty, we have compiled a trouble-shooting chart to assist your service personnel. If additional assistance is required contact Kooltronic at (609) 466-3400.

Problem	Cause	Solution
Unit not Cooling	No Power	Check Power Source and Electrical Connections
	Loss of Refrigerant	Locate and repair leak
	Evaporator or Condenser Blower not operating	Replace Motor, Capacitor or entire Assembly
	Filter clogged	Clean or replace Filter
	Clogged Evaporator or Condenser Coil	Clean Coil
	Low Temperature Control (Thermostat) improperly set	Lower setting until unit starts
	Low Temperature Control (Thermostat) defective	Replace Thermostat or Relay when applicable
	Failed Compressor	Replace Compressor
Ice on Evaporator Coil	Insufficient Heat Load or Unit Oversized for Application	Contact Kooltronic
	Failed Evaporator Blower	Replace Evaporator Blower Motor or Assembly
	Clogged Evaporator Coil	Clean Coil
Condensate draining continuously	Enclosure not properly sealed	Check and seal all openings
	Excessive opening of Enclosure	Eliminate the frequency of door opening
Excessive vibration	Defective Motor in Blower	Replace Motor
	Defective Wheel in Blower	Replace Wheel
	Compressor Loose	Tighten Mounting Bolts
Compressor Inoperative	Low line Voltage	Check Nameplate Voltage against supply
	Loss of Compressor Oil	Replace Compressor
	Loss of Refrigerant	Locate and repair leak
	Failed Compressor Capacitor	Replace Capacitor
	Thermal Overload	Contact Kooltronic
	Power interruptions	Allow Compressor time to reset
Refrigerant or Oil leaks	Crack or pin hole in tubing or brazed joint	Replace tubing or rebrase joint

X. Standard Warranty

KOOLTRONIC products are warranted to be free of defects in workmanship, materials and components. The following warranty periods apply from date of shipment:

- Air moving devices/components and hermetic system components: 1 year
- Spare parts, except filters: 90 days

The above warranty applies when the equipment is operated under the following conditions:

- Ambient temperature not in excess of 125°F (52°C) in normal atmosphere or as stated on product nameplate
- Voltage variation no greater than $\pm 10\%$ from nameplate rating
- Frequency variation no greater than $\pm 3\text{Hz}$ from nameplate rating
- Maximum cooling load no higher than air conditioner nameplate rating
- Waiting five minutes before restarting air conditioner after intentional or accidental shutoff
- Compliance to all other installation, maintenance and operating instructions, as supplied
- The purchaser assumes the responsibility of grounding the unit and installing it in accordance with local electrical and safety codes, as well as the National Electric Code (NEC) and OSHA

KOOLTRONIC cannot assume responsibility for mis-application of its products or the erroneous selection of an inappropriate product by a non-authorized KOOLTRONIC representative. Our applications engineers will gladly assist in the selection of the proper product, provided all required details of the application are furnished.

THIS WARRANTY CONSTITUTES THE ENTIRE WARRANTY WITH RESPECT TO THE PRODUCT AND IS IN LIEU OF ALL OTHERS, EXPRESSED OR IMPLIED, INCLUDING ANY WARRANTY OF MERCHANTABILITY AND WARRANTY OF FITNESS FOR A PARTICULAR PURPOSE AND IN NO EVENT IS KOOLTRONIC RESPONSIBLE FOR ANY CONSEQUENTIAL DAMAGES OF ANY NATURE WHATSOEVER.

RETURN AUTHORIZATION (RA) PROCEDURE

- All returns require a Return Authorization number whether the return is for warranty or non-warranty repair, rotation of stock, damage or any other reason. Returns without an RA number will be refused.
- Customer must call KOOLTRONIC After Sale Kare (ASK), Pennington, New Jersey (609 • 466 • 3400) to obtain an RA number, or email ask@kooltronic.com.
- The following information is required when an RA is requested:
 - Original customer Purchase Order number and date
 - Date product was received by customer
 - Number of parts to be returned
 - Product description, model and serial number
 - Reason for return
 - Action requested
 - Contact name, telephone, FAX numbers and e-mail address
- Pack unit in a suitable container for shipment, preferably the

KOOLTRONIC assumes no liability beyond the repair or replacement of its own product. This Warranty does not cover:

- Labor or reimbursement of labor for evaluation, removal, installation, repair, or cost of any warranted part, unless authorized in writing by KOOLTRONIC
- Use of equipment for other than its designed purpose or operating conditions
- Operation in harsh, oily, corrosive or other abnormal environmental conditions, without the proper filtration, sealing, protective coatings and/or weather protection
- Damage to hermetic system resulting from continuous operation with dirty or clogged air filters or improper or negligent maintenance
- Use of refrigerant other than designated
- Customer modification or abuse
- Shipping damage or other accident (Claims for shipping damage are the responsibility of the customer. Timely claims must be filed by the customer with the freight carrier)
- Cracked or broken hermetic tubing, brazed joints or other internal damage caused by shipping or mishandling
- Damage caused by shipping units attached to an enclosure
- Any and all conditions resulting from noncompliance with the preceding operating conditions
- Returned freight must be paid by customer
- **This standard warranty does not apply to custom products. Consult your KOOLTRONIC representative for limitations**

original packaging if available. All Air Conditioners must be returned in an upright position properly secured to a pallet. **Improper packaging may void warranty claim.** If an Air Conditioner is received laying down or shipped via UPS or similar small parcel service the warranty will be void.

- Mark carton prominently with KOOLTRONIC's Return Authorization Number.
- Enclose all pertinent documents.
- Freight charges on all products returned to KOOLTRONIC shall be paid by the customer. Unauthorized collect shipments will be refused.
- If a unit is repaired under Warranty, KOOLTRONIC will pay the freight charges both ways within the Continental USA at KOOLTRONIC's negotiated rates. Warranty repaired units will be returned to customer at KOOLTRONIC expense only within the Continental USA.
- All authorized returns are subject to a restocking fee.