



**GUARDIAN SERIES  
K\_NA4C7DP43L**

**Keep This Manual  
With Air Conditioner**

Find additional information on this model at [kooltronic.com](http://kooltronic.com) or use the Technical Documents QR code below.

Technical Documents



# **AIR CONDITIONER OPERATOR'S MANUAL**

## **CAUTION**

**BEFORE INSTALLING AND USING THIS AIR CONDITIONER, IT IS IMPORTANT THAT THIS MANUAL BE READ AND UNDERSTOOD THOROUGHLY**



**KOOLTRONIC, INC.**  
**30 Pennington-Hopewell Road**  
**Pennington, NJ 08534**  
**609•466-3400**  
**FAX: 609•466-1114**  
**[www.kooltronic.com](http://www.kooltronic.com)**

# **TABLE OF CONTENTS**

		Page
I.	Introduction	2
II.	Incoming Inspection	3
III.	Product Handling	3
IV.	Product Identification and Nameplate	4
V.	Principles of Operation	5 - 8
VI.	Pre-Installation Testing	9
VII.	Specific Model Data	10 - 13
	Mounting	
	Drawings and Dimensions	
	Technical Data	
	Major Component Replacements	
	Standard Features	
VIII.	Maintenance	14 - 15
IX.	Trouble Shooting	15 - 16
X.	Warranty	17

**NOTE:** Wiring Schematics are available on the specific model page of the Kooltronic website.

## ***I. Introduction***

Kooltronic Air Conditioners are designed to provide a cool, dehumidified environment for your electronic components. There are models to fit virtually all sizes and shapes of electronics enclosures, in capacities ranging from 1,000 to 30,000 BTU/H. Our "closed-loop" design also ensures that your components will not be exposed to hot, dirty operating conditions.

This Manual provides you with the necessary general information for properly installing and operating standard Kooltronic Air Conditioners. Technical data and mounting instructions are presented on pages 10 through 13.

## **II. Incoming Inspection**

Kooltronic Air Conditioners are designed, built and packaged to withstand the shock and vibration normally associated with shipment by common carriers. Occasionally improper handling during shipping causes damage. Such handling could include unbanding of palletized shipments, failing to respect "**This Side Up**" arrows, rough handling, falling off conveyors, excessive vibration, crushing, etc. Therefore, a thorough inspection should be done upon receipt of all shipments. Any carton tears, dents, scratches, loose articles or evidence of oil are signs of damage and should be noted on the Freight Bill. Cartons should be opened promptly and the units inspected for CONCEALED DAMAGE. Kooltronic Air Conditioners must be delivered in the proper mounting position to assure that damage to the compressor has not occurred during shipping. Any Kooltronic Air Conditioner that is delivered removed from the banded pallet, lying down or double stacked should be refused.

An immediate claim **MUST** be filed with the freight carrier and an inspection requested. Retain all packing materials. Kooltronic cannot assume responsibility for Consignee's failure to file a timely freight claim.

## **III. Product Handling:**

- 1) Do not attempt to operate your Kooltronic Air Conditioner until you read and thoroughly understand this Manual. See section **VI PRE-INSTALLATION TESTING**.
- 2) Before operating the Kooltronic Air Conditioner be certain that it is placed in its correct mounting position. **This Air Conditioner is designed to operate in a vertical position only.** This placement must be done a minimum of 5 minutes prior to operating in order to allow the compressor oil to drain to the compressor sump area.

### **CAUTION**

**Kooltronic Air Conditioners must be operated in their proper mounting position. If attempts are made to operate a unit that is not in its designed mounting position, permanent compressor damage will occur. This action will void the warranty. To avoid compressor damage do not tip the unit more than 45° from its proper mounting position.**



- 3) Before operating this unit, all electrical wiring must be checked to assure the proper connection to the correct power source. Minimum circuit ampacity should be at least 125% of the amperage found on the nameplate for the corresponding voltage. Do not exceed the maximum fuse size found on the nameplate.
- 4) We do not recommend that Air Conditioners be shipped to their final destination attached to an enclosure. In the event that the Air Conditioner needs to be shipped attached to an enclosure it is strongly recommended that proper support be provided for the Air Conditioner. Excessive vibration can occur if Air Conditioners are not properly supported when shipped on enclosures, increasing the potential for internal damage and voiding the warranty.
- 5) **PROCEDURE FOR PROPER PACKING AND SHIPMENT OF KOOLTRONIC AIR CONDITIONERS:**
  - Keep Air Conditioner in proper upright position indicated by arrow markers.
  - Pack Air Conditioner in an appropriate carton (preferably original carton if possible), with adequate internal protective packaging, making sure carton is marked and is kept in correct upright position.
  - For local, controlled transportation, strap carton to a secure part of truck to prevent falling or sliding, minimize vibration, etc.
  - For common carrier shipment, band unit(s) securely to a pallet. Unpalletted shipment risks severe damage which voids the warranty.

## IV. Product Identification and Nameplate

Each Kooltronic Air Conditioner includes an identification nameplate. This nameplate provides:

- ① Model Number
- ② Serial Number
- ③ Electrical power characteristics
- ④ Maximum and minimum ambient operating temperatures
- ⑤ Cooling capacity
- ⑥ Type and amount of refrigerant required for recharging
- ⑦ Design Pressure
- ⑧ Maximum Fuse Size
- ⑨ Manufacturing Order Number
- ⑩ Filter
- ⑪ Underwriters Laboratories Inc. Listed or Recognized Marks and NEMA ratings

We recommend you copy this information from your unit.

		Air Conditioner			
VOLTS ③	FREQ. ③	PH. ③	COOLING F.L.A. ③	AMBIENT TEMP. MIN. °F    MAX. °F ④            ④	
COOLING BTU ⑤		REFRIGERANT    Oz. ⑥			
DESIGN PRESSURE P.S.I.G. LOW                      HIGH ⑦                            ⑦		MAX. FUSE SIZE ⑧		 <b>LISTED 84H7 SPECIAL PURPOSE AIR CONDITIONER</b> ⑪	
		MFG. ORDER NO. ⑨			
		FILTER P/N ⑩			
<p><b>SPECIAL PURPOSE AIR CONDITIONER</b> NEMA/EEMAC/UL50 BY UNDERWRITERS LABORATORIES, INC. TYPE 3R, 12 &amp; 4 INTERFACE TO THE ELECTRICAL ENCLOSURE ONLY</p> <p>NEMA/EEMAC/UL50 BY UNDERWRITERS LABORATORIES, INC. TYPE 1 SPECIAL PURPOSE AIR CONDITIONER EQUIPMENT COMPARTMENT ONLY OUTDOOR USE</p> <p>SERVICE AIR FILTER REGULARLY ALLOW 5 MIN. BEFORE RESTARTING AFTER SHUTDOWN UNAUTHORIZED SERVICE OR MODIFICATION VIOLATES WARRANTY ALL MOTORS ARE THERMALLY PROTECTED</p> <p><b>MANUFACTURED BY:</b> Kooltronic, Inc.    PENNINGTON, NJ</p>					
					

①②⑨ When ordering parts, specify the Model Number, Serial Number & MFG. Order Number.

③ Before operating, be sure that the power source matches these requirements.

④ Make sure that these parameters are met. Failure to do so may result in permanent damage to the unit.

⑥ Use of incorrect type or amount of refrigerant will adversely affect performance and may damage the unit.

# V. Principles of Operation

Kooltronic Air Conditioners are required when the equipment operating temperature must be kept near or lower than the ambient room temperature, and/or the cabinet must be sealed from dust, fumes, oil, corrosives and other contaminants. These Air Conditioners utilize a "Closed-Loop Cooling System" to ensure optimum performance of the installed components.

Closed-Loop cooling seals the electronic enclosure from hostile elements in the environment. Two separate circulation systems are employed. The internal system cools and dehumidifies the air inside the cabinet, totally isolating the sensitive electronics and other components from the environment. The external system uses circulating ambient air or water to discharge the heat removed from the electronics. The heat is dissipated from the enclosure by means of the vapor compression refrigeration cycle. This takes place in a hermetically-sealed refrigeration system, utilizing either an air-cooled or water-cooled condenser heat exchanger. The warm air inside the enclosure is drawn through the evaporator coil where it is cooled, dehumidified and returned.

Any enclosure moisture accumulated on the evaporator coil is collected in the condensate tray and removed through the drain tube to the condensate evaporator. Condensate evaporates in the condensate evaporator and is released to the ambient air by the condenser impeller.

The heat removed through the evaporator coil is transferred by the compressed refrigerant to the condenser coil. Ambient air is then passed through the condenser coil, where it absorbs the heat and is then discharged to the environment.

When the Kooltronic Air Conditioner is properly sized it should operate constantly and maintain 75°F to 115°F enclosure temperature, depending on the ambient temperatures.

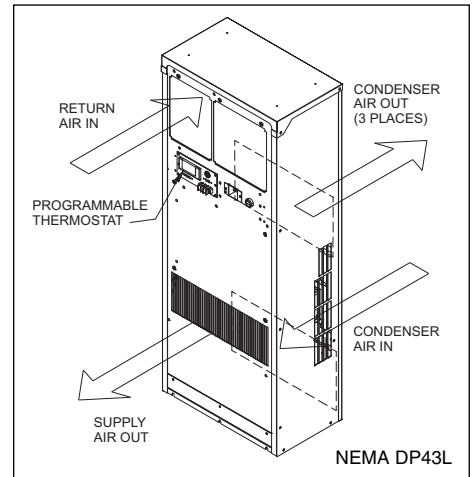

## UNITS EQUIPPED WITH PROGRAMMABLE THERMOSTAT

For units equipped with Low Temperature Thermostat, see page 8.

## CONTROL ACTION

The evaporator blower operates continuously. The compressor is cycled on and off by the action from the factory preset programmable thermostat. A pressure switch controls the on/off action of the condenser blower.

The regulation is performed according to the temperature measured by the thermostat probe with a positive differential from the set point: if the temperature increases and reaches set point plus differential the compressor is started and then turned off when the temperature reaches the set point value again.

In case of fault in the thermostat probe the start and stop of the compressor are timed through preset parameters.

The programmable thermostat is located as shown in the upper right ISO illustration. **WARNING:** the programmable device is preprogrammed and set at the factory. In the event changes are needed the following instructions can be used.

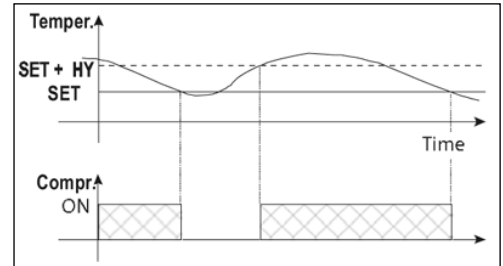

## FRONT PANEL COMMANDS



### KEY COMBINATIONS

- + To lock and unlock the keyboard.
- SET** + To return to the room temperature display.
- SET** + To enter programming mode.

- SET** - To display target set point; in programming mode it selects a parameter or confirms an operation.
- (**UP**) - To see the max. stored temperature; in programming mode it browses the parameter codes or increases the displayed value.
- (**DOWN**) - To see the min. stored temperature; in programming mode it browses the parameter codes or decreases the displayed value.
- To switch the instrument off, if onF = OFF.
- Not enabled.
- (**DEF**) - To start a manual defrost.

## FRONT PANEL LED INDICATORS

LED Functions		
LED	MODE	FUNCTION
	ON	Compressor enabled
	Flashing	Anti-short cycle delay enabled
	ON	An alarm is occurring
	ON	Continuous cycle is running (not enabled)
	ON	Energy saving (not enabled)
'F'	ON	Measurement unit
'F'	Flashing	Programming phase

# Principles of Operation (con't)

## MAX AND MIN TEMPERATURE MEMORIZATION

### HOW TO SEE THE MIN TEMPERATURE:

- 1) Press and release the down arrow ▼ key.
- 2) The "Lo" message will be displayed followed by the minimum temperature recorded.
- 3) Press the down arrow ▼ key again or wait 5 seconds to restore normal display.

### HOW TO SEE THE MAX TEMPERATURE:

- 1) Press and release the up ▲ arrow key.
- 2) The "Hi" message will be displayed followed by the maximum temperature recorded.
- 3) Press the up arrow ▲ key again or wait 5 seconds to restore normal display.

### HOW TO RESET THE MAX AND MIN TEMPERATURE RECORDED:

- 1) Press the SET key for more than 3 seconds while the max or min temperature is displayed. (rSt message will be displayed.)
- 2) To confirm the operation, the "rSt" message starts blinking and the normal temperature will be displayed.

## MAIN FUNCTIONS

### HOW TO SEE THE SETPOINT:

- 1) Press and immediately release the SET key. The display will show the set point value.
- 2) Press and immediately release the SET key, or wait 5 seconds to display the probe value again.

### HOW TO CHANGE THE SETPOINT:

NOTE: The standard set point is 75°.

- 1) Press the SET key for more than 2 seconds to change the set point value.
- 2) The value of the set point will be displayed and the °C or °F LED starts blinking.
- 3) To change the set value push the up ▲ or down arrow ▼ keys within 10 seconds.
- 4) To store the new set point value push the SET key again, or wait 10 seconds.

### HOW TO CHANGE A PARAMETER VALUE:

To change a parameter's value, operate as follows:

- 1) Enter the Programming mode by pressing the SET plus down arrow keys for 3 seconds (the °C or °F LED starts blinking).

- 2) Select the required parameter. Press the SET key to display its value.
- 3) Use up or down arrow keys to change its value.
- 4) Press SET to store the new value and move to the following parameter. To exit, press SET and the up arrow keys or wait 15 seconds without pressing a key.

NOTE: The set value is stored even when the procedure is exited by waiting for the time-out to expire.

### HOW TO LOCK THE KEYBOARD:

- 1) Press and hold the up and down arrow keys simultaneously for more than 3 seconds.
- 2) The POF message will be displayed, and the keyboard will be locked. At this point, it will only be possible to see the set point or the MAX or MIN temperature stored.
- 3) If a key is pressed more than 3 seconds, the POF message will be displayed.

### HOW TO UNLOCK THE KEYBOARD:

- 1) Press and hold the up and down arrow keys simultaneously for more than 3 seconds until the Pon message is displayed.

## OPTIONAL MONITORING SYSTEM

### TTL SERIAL LINE - FOR OPTIONAL MONITORING SYSTEMS:

The optional TTL serial line, available through the HOT KEY connector, allows through the use of the external TTL/RS485 converter, connection of this digital converter to a monitoring system that is ModBUS-RTU compatible (X-WEB500/3000/300). Connections are provided through an external 2-position terminal block.

# Principles of Operation (con't)

## RESETTING

If it becomes necessary to reset the unit, the factory settings are as follows:

PARAMETER	DESCRIPTION	VALUE	UNIT	RANGE	
				MINIMUM	MAXIMUM
SEt	Set Point	75	°F	60	95
Hy	Differential	10	°F	1	45
dP4	Fourth probe display	0	--	--	--
dP3	Third probe display	0	--	--	--
dP2	Evaporator probe display	0	--	--	--
dP1	Room probe display	0	--	--	--
AFH	Differential for temperature alarm recovery	2	°F	1	45
ALL	Minimum temperature alarm	35	°F	-67	120
ALU	Maximum temperature alarm	120	°F	35	302
SHy	Differential for auxiliary relay	5	°F	1	45
SAA	Set point for auxiliary relay	115	°F	-67	302
ACH	Kind of action for auxiliary relay	CL	--	--	--
AC	Anti-short cycle delay	2	min	0	50
odS	Outputs delay at start up	0	min	0	255
P2P	Evaporator probe presence	n	--	--	--
ot	Thermostat probe calibration	0	°F	-21	21
US	Maximum set point	95	°F	75	302
LS	Minimum set point	60	°F	-67	75
Ptb	Map code	7	--	0	65535
rEL	Software release	0	--	--	--
rSE	Real set point	0	--	--	--
onF	on/off key enabling	ES	--	--	--
PbC	Kind of probe	ntc	--	--	--
Adr	Serial address	1	--	1	247
HES	Differential for energy saving	0	°F	-54	54
rrd	Regulation restart with door open alarm	y	--	--	--
odc	Compress status when open door	no	--	--	--
nPS	Number of activation of pressure switch	15	--	0	15
did	Digital input alarm delay	5	min	0	255
i1F	Digital input configuration	EAL	--	--	--
i1P	Digital input polarity	cL	--	--	--
dAO	Delay of temperature alarm at startup	00:00	h	--	--
ALd	Temperature alarm delay	0	min	0	255
ALc	Temperature alarms configuration	Ab	--	--	--
ArP	Probe selection for auxiliary alarm	P1	--	--	--
dLy	Display temperature alarm	00:00	min.	0	20
Lod	Probe displayed	P1	--	--	--
rES	Resolution	in	--	--	--
CF	Temperature measurement unit	F	--	--	--
CH	Kind of action: heating cooling	cL	--	--	--
COF	Compressor OFF time with faulty probe	4	min	0	255
COn	Compressor ON time with faulty probe	20	min	0	255
O4	Fourth probe calibration	0	°F	-21	21
P4P	Fourth probe presence	n	--	--	--
O3	Third probe calibration	0	°F	-21	21
P3P	Third probe presence	n	--	--	--
OE	Evaporator probe calibration	0	°F	-21	21

## Principles of Operation (con't)

### UNITS EQUIPPED WITH LOW TEMPERATURE THERMOSTAT

A Low Temperature Thermostat prevents the evaporator coil from freezing. In conditions of low ambient temperature and low enclosure load, the thermostat regulates the return air temperature from 75°F to 86°F. The standard set point of the Low Temperature Thermostat is 75°F. The set point can be changed to 70°F or to 79°F by changing the location of the thermostat jumper (See illustrations on page 11).

The Low Temperature Thermostat has a test start relay. When the air conditioner is turned on it will run constantly for the first 15 minutes regardless of external temperatures. Afterwards, if the entering evaporator air temperature is lower than the thermostat set point, the compressor and condenser blower will stop, and the thermostat will begin to control the air conditioner.

The heater kit consists of a heater, a heat control thermostat and a heater limiter. The heater control thermostat is a bimetal disk with a fixed set point of 60°F. When the entering evaporator air temperature rises above 60°F the heater shuts off, and when the evaporator air temperature falls below 40°F the heater will engage. The contact points of the alarm thermostat are normally closed. If the entering evaporator air temperature exceeds 130°F the alarm thermostat contacts open, and when the temperature drops below 130°F the contacts close. In applications having frequent voluntary heat load fluctuations, an optional Compressor Short Cycle Protector is recommended.

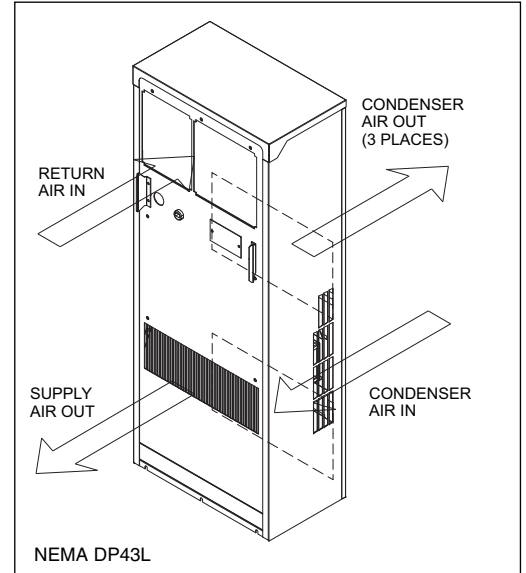



## ***VI. Pre-Installation Testing***

Before mounting the air conditioner to the enclosure, test for proper operation. This will verify the shipping integrity of the system. Please follow the steps below prior to installation.

### ***CAUTION***

**The air conditioner must be standing in its proper mounting position for a minimum of five (5) minutes prior to testing. Failure to follow this procedure will cause permanent damage to the compressor. To avoid compressor damage do not tip the unit more than 45° from its proper mounting position.**

1. The unit must sit in an upright position at a minimum room temperature of 65°F to allow the system to warm up. This is particularly important during winter months.
2. Refer to the nameplate for proper electrical voltage and current requirements. Connect the power cord to a properly grounded and fused electrical supply, leaving electrical power to the unit turned off.
3. Note the factory thermostat setting which is 75°F.
4. Turn the electrical power on.
5. Verify that the evaporator blower or fan is running.
6. Verify that the condenser blower or fan is running.

**NOTE: Models with Programmable Thermostat follow 7 through 10. Models with Low Temperature Thermostat, follow 8 through 10.**

7. Observe the temperature on the digital display. The thermostat must be set a minimum of 10°F below this temperature for the compressor to operate (the factory setting is 75°F). Refer to page 6 for instructions on adjustment of the thermostat.
8. Operate the air conditioner for approximately ten (10) minutes. During this period no unusual noise or vibration should be evident. Both the evaporator and condenser fans or blowers should be delivering air through their respective discharge ports. The cool air discharged should be less than 70°F when the room temperature is between 70°F and 80°F. It is normal for the condenser blower to cycle on/off during this period.
9. Turn off the electrical power and disconnect the air conditioner from the power source.
10. If a cover plug was removed to adjust the unit, be sure to replace it in order to maintain the integrity of the closed-loop airflow system.

**NOTE:** Before shipment all Kooltronic Air Conditioners are subjected to a performance test.

## VII. Specific Model Data

### Mounting

The Kooltronic Special Purpose Air Conditioners K\_NA\_C7DP43L have been engineered to be installed easily. Prior to mounting, refer to page 11 and 12 for the mounting plan and the general arrangement drawings showing dimensions and locations of mounting holes and cutouts. Prior to cutting or drilling, make sure that cutouts and mounting holes do not interfere with components inside the cabinet. To avoid damaging your air conditioner, please read the following information before installation:

1. These externally mounted air conditioners have two gasket layers to ensure a proper seal. This seal is necessary to maintain the integrity of the closed-loop system and the enclosure NEMA 4 or NEMA 4X Rating.
2. Attach two hooks to the air conditioner using two #10 torx screws for each hook.
3. Hang the air conditioner on the enclosure upper cutout.
4. Secure the air conditioner to the enclosure using (7)  $\frac{1}{4}$ -20 x  $1\frac{1}{4}$ -inch stainless steel bolts at the top and middle of the unit. Use (3) stainless steel bolts  $\frac{1}{4}$ -20 x  $1\frac{1}{4}$ -inch and (3) stainless steel nuts  $\frac{1}{4}$ -20 on the bottom of the air conditioner.
5. Attach plastic drain hose to the drain tubing on the bottom of the air conditioner with a clamp.

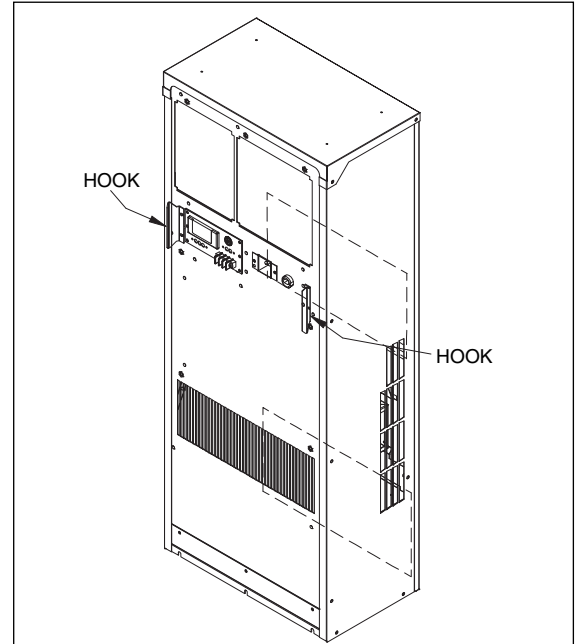

### CAUTION

**If the air conditioner is mounted to the cabinet door you must be sure that the door hinges will support the additional weight of the air conditioner. Also be certain that when the door is opened fully, the cabinet does not become unbalanced. The actual weight of the unit can be found in the Technical Data on page 13.**

# Drawings and Dimensions

## MOUNTING PLAN

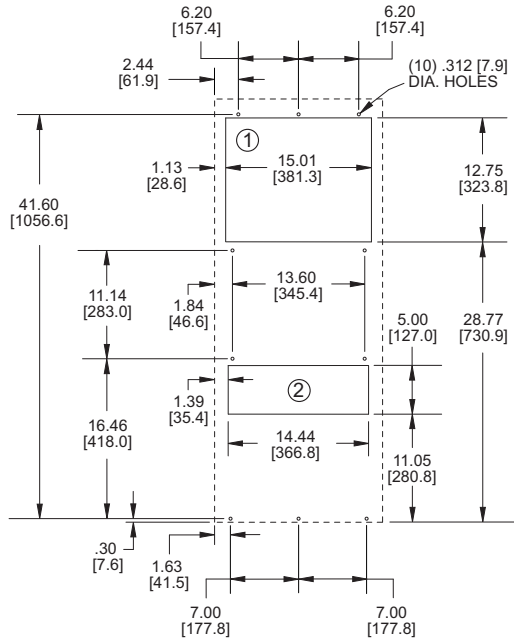

- ① WARM AIR RETURN FROM ENCLOSURE
- ② COOL AIR OUTLET TO ENCLOSURE

Dimensions, inches [mm], are for reference only and are subject to change.

**K\_NA4C7DP43L-LV**

## ELECTRONIC THERMOSTAT CONTROL

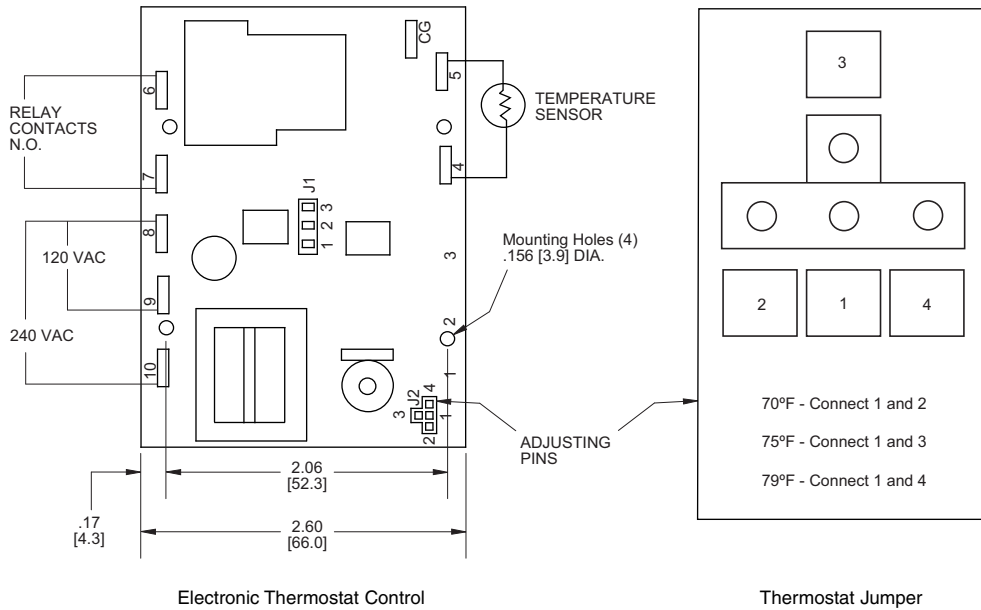

Dimensions, inches [mm], are for reference only and are subject to change.

# Drawings and Dimensions

K\_NA4C7DP43L-LV

- ① CONDENSER AIR INLET  
(Ambient Air In)
- ② CONDENSER OUTLET  
(Warm Ambient Air Out)
- ③ WARM AIR RETURN FROM  
ENCLOSURE
- ④ COOL AIR OUTLET  
TO ENCLOSURE

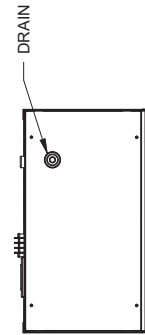
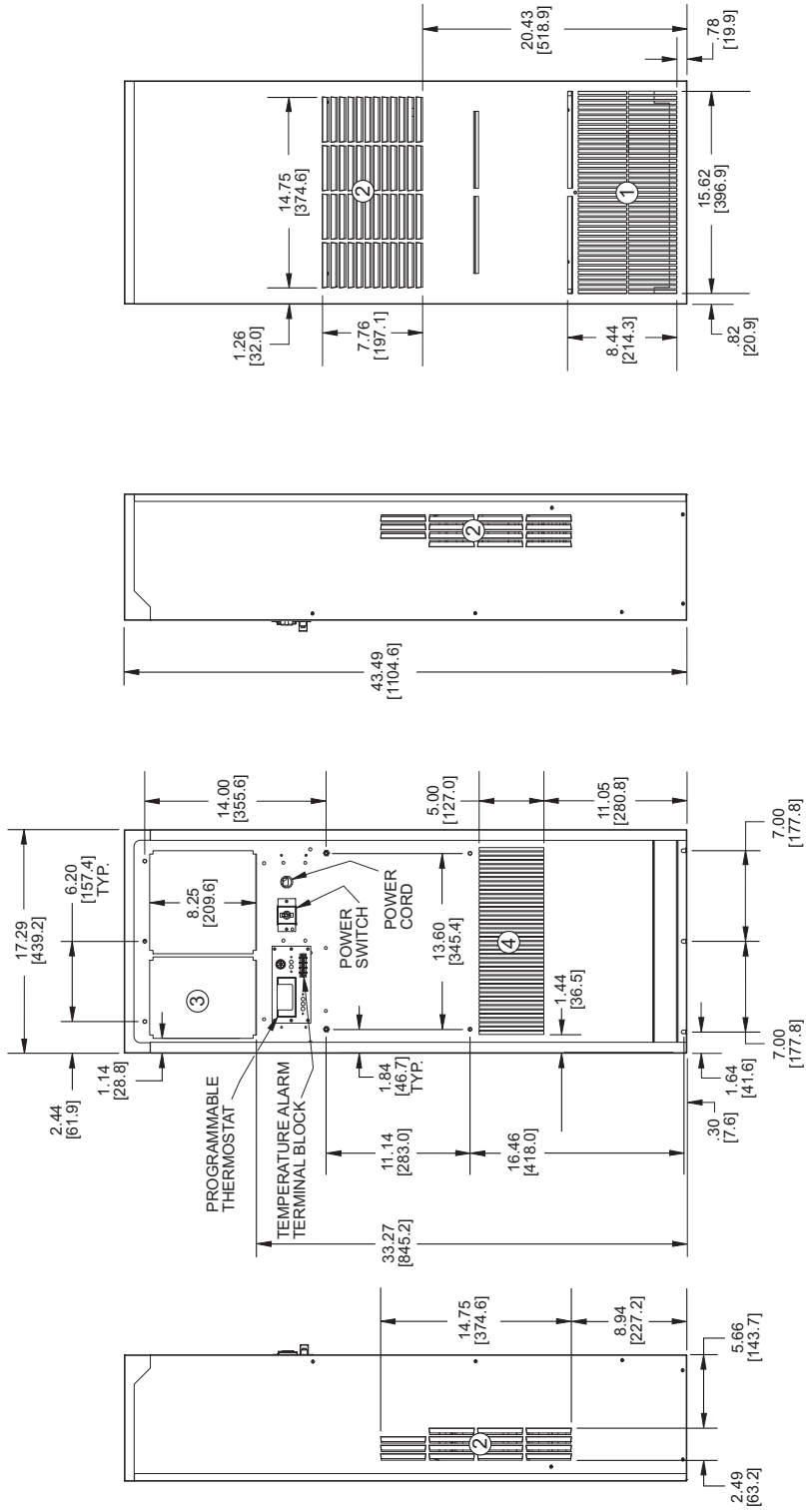
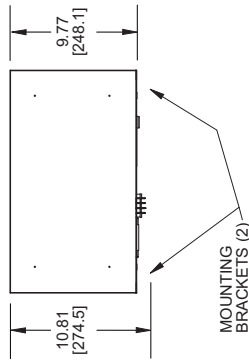

Dimensions, inches [mm], are for reference only and are subject to change.

GA26701A

## Technical Data

Model	NEMA Rating	BTU/H Capacity	BTU/H 95°F/95°F	Ambient Temp. °F Max./Min.	Volts	Hz	Running Amps 131°F/131°F	Approximate Weight (lbs.)
KNA4C7DP43L	4	7000	5500	131/-20	115/100	60/50	13.8/13.6	125
K2NA4C7DP43L	4	7000	5500	131/-20	230/200	60/50	6.7/6.6	125
KNA4C7DP43LV	4X	7000	5500	131/-20	115/100	60/50	13.8/13.6	125
K2NA4C7DP43LV	4X	7000	5500	131/-20	230/200	60/50	6.7/6.6	125

## Major Component Replacements

Part	KNA4C7DP43L KNA4C7DP43LV (Units with Low Temperature Thermostat) Part Number	KNA4C7DP43L KNA4C7DP43LV (Units with Programmable Thermostat) Part Number	K2NA4C7DP43L K2NA4C7DP43LV (Units with Low Temperature Thermostat) Part Number	K2NA4C7DP43L K2NA4C7DP43LV (Units with Programmable Thermostat) Part Number
Compressor	0665-119	0665-119	0665-120	0665-120
Compressor Run Capacitor	0452-54	0452-54	0452-12	0452-12
Condenser Impeller	0194-103	0194-103	0194-50	0194-50
Condenser Impeller Capacitor	0452-32	0452-32	0452-06	0452-06
Condenser Speed Controller	0750-108	N/A	0750-108	N/A
Evaporator Impeller	0194-14	0194-14	0194-15	0194-15
Evaporator Impeller Capacitor	0452-06	0452-06	0452-73	0452-73
Condenser Coil	0666-12	0666-12	0666-12	0666-12
Evaporator Coil	0667-53	0667-53	0667-53	0667-53
Low Temperature Thermostat	0750-104	N/A	0750-104	N/A
Programmable Thermostat	N/A	0750-136	N/A	0750-137

## Standard Features

Baked Powder Finish (NEMA 4 models)  
 Built-in Condensate Evaporator  
 CFC- Free Refrigerant  
 Closed-Loop Cooling  
 Compressor Short Cycle Protector  
 Condenser Impeller Speed Controller  
 Epoxy-Coated Condenser and Evaporator Coils  
 Filter  
 Heavy-duty Steel Shell (NEMA 4 models)  
 Internal Corrosion Protection (NEMA 4X models)  
 NEMA 12, 3R and 4 Ratings Maintained (UL50)  
 Programmable Temperature Alarm  
 Programmable Thermostat Available  
 Six-Foot [1.8m] (minimum) 3-Wire Power Cord  
 Stainless Steel Shell (NEMA 4X models)  
 UL/CUL Listed

## Accessories and Options

Enclosure Heater  
 Filter Recoating Adhesive  
 Lead-Lag Controller  
 Remote Monitoring  
 Remote Thermostat Relay  
 Replacement Filters  
 Special materials or finishes  
 Special motors, line cords or connectors

## GuardianX NEMA 4X model offered with these additional features

NEMA 4X Rating Maintained (UL50)  
 Internal Corrosion Protection  
 Stainless Steel Shell

## **VIII. Maintenance**

Kooltronic Air-Cooled Air Conditioners require routine cleaning of the condenser coil and the air filters to assure unimpeded airflow through the condenser heat exchanger. It is not possible to recommend specific condenser coil or filter cleaning intervals, since the level and the nature of airborne particulate matter differs widely with each installation. It is generally sufficient to clean the condenser coil and/or the aluminum mesh filter when the outer surfaces appear covered with a thin layer of dust, lint or other foreign matter. The condenser coil can be washed or blown out with air, depending on the foreign matter involved (see below - **Filter and condenser coil service**). The aluminum mesh filter can be washed with warm water. Appropriate disposable replacement filters are available from Kooltronic.

If routine condenser coil or filter service is neglected or delayed, the air conditioner will not perform at its design capacity. The first indication of an excessively clogged condenser coil or air filter is usually a gradual increase of temperature within the equipment cabinet. If operation is continued under these conditions, the compressor will be shut off by the thermal overload device. The compressor will restart when its external temperature drops below the protector threshold setting and the compressor will continue to cycle on and off. Continued operation under these conditions will cause damage, shorten compressor life and void the warranty.

### **A. Filter and condenser coil service**

The rear panel must be removed in order to clean the filters. After removal, the filters should be flushed under warm running water with clean side up. If the accumulated dirt is oily, washing in a detergent bath is recommended, followed by a warm water wash as above.

The exposed condenser coil must be cleaned by pressurized air or pressurized cleaning solution. Dirty liquid will be removed through the condenser coil drain pan.

### **B. Blowers**

The design life of the blowers used in all Kooltronic Air Conditioners is substantially in excess of 20,000 hours. All Kooltronic condenser and evaporator blowers are equipped with automatic-reset thermal overload protectors.

## **CAUTION**

**Before opening the air conditioner, disconnect all power.**

If field replacement of a blower motor is necessary, most blower assemblies, including the mounting plate, are readily removable. Each of the blower mounting plates is held to the air conditioner cabinet structure by screws and nuts. For installation of the replacement blower, electrical connections may be broken at the terminal block, or power leads may be cut and appropriately spliced together.

### **C. Compressor**

All Kooltronic compressors are approved by UL and CSA, and require no maintenance. They are hermetically sealed and charged at the factory, and equipped with automatic-reset thermal overload protectors.

If the compressor fails, it is strongly recommended that the air conditioner be returned to Kooltronic for service.

## D. Refrigerant Loss

Kooltronic Air Conditioners are subjected to a series of tests to detect refrigerant leaks, during and after manufacture. It is possible that shipping or other damage, or microscopic leaks over a long period, may result in the need for replenishment of refrigerant charge. **When it has been verified by a Certified EPA Technician that a refrigerant shortage does exist, the leak must be repaired. Then the unit may be evacuated and recharged in the field by a Certified EPA Technician only.**

### **CAUTION**

**Refer to the data on the unit nameplate which specifies the type of refrigerant and the amount of charge in ounces.**

## E. Relocation

If your Kooltronic Air Conditioner has to be moved to another location by truck, the following precautions should be taken:

- De-mount the air conditioner from the equipment, controller or enclosure.
- Conform to the applicable provisions of PROCEDURE FOR PROPER PACKING AND SHIPMENT OF KOOLTRONIC AIR CONDITIONERS in this manual under *Section III. "PRODUCT HANDLING"*.

## **IX. Trouble-Shooting**

Each Kooltronic Air Conditioner is engineered for performance and built for reliability. They are designed to require only routine maintenance. If your air conditioner should require warranty service, please contact Kooltronic. If you require service out of warranty, we have compiled a trouble-shooting chart to assist your service personnel. If additional assistance is required contact Kooltronic at (609) 466-3400.

<b>Problem</b>	<b>Cause</b>	<b>Solution</b>
<b>Unit does not run.</b>	No Power.	Check Power Source and electrical connection. Check unit ON-OFF switch (UL Listed units only). Check unit power cord connection to terminal block.
<b>After initial 15 minute energization of air conditioner, compressor and condenser fan do not run.</b>	Return temperature is between Thermostat set point and differential (75°F to 86°F).	Normal Operation. Check return air temperature. Check sensor connection on Thermostat.
<b>Unit not cooling. (Temperature difference between return and supply air is less than 10°F).</b> Evaporator Blower is running. Compressor and Condenser Blower do not run. Return temperature is above set point plus differential (90°F).	Failed Thermostat or Relay.  Low Line Voltage.  Failed Compressor.	Check Thermostat and Relay wire connections. Replace Thermostat or Relay.  Check Nameplate Voltage against supply Voltage.  Check Compressor wire connections. Check Compressor overload. Check Compressor Capacitor. Replace Compressor.

<b>Problem</b>	<b>Cause</b>	<b>Solution</b>
<b>Unit not cooling. (Temperature difference between return and supply air is less than 10°F).</b> Compressor and Condenser Blower are running. Evaporator Blower does not run.	Failed Evaporator Blower.	Check Blower wire connections. Check blower capacitor. Replace Evaporator Blower.
<b>Unit not cooling. (Temperature difference between return and supply air is less than 10°F).</b> Compressor and Evaporator Blower are running. Condenser Blower does not run.	Low Refrigerant charge. Failed Condenser Blower. Failed Speed Controller.	Check discharge and suction pressure for Refrigerant leak. Check Blower wire connections. Check Blower Capacitor. Replace Condenser Blower. Check Speed Controller Sensor. Replace Speed Controller.
<b>Unit not cooling. (Temperature difference between return and supply air is less than 10°F).</b> Evaporator Blower, Condenser Blower and Compressor are running.	Condenser or Evaporator Coil clogged. Loss of Refrigerant. Ice on Evaporator Coil. Excessive condensate draining and loss of A/C sensible cooling performance.	Clean Coil. Locate and repair leak. Clean Evaporator Coil. Check discharge and suction pressure for Refrigerant leak. Check for any obstruction of Evaporator airflow. Check and seal all openings. Eliminate the frequency of door openings.
<b>Unit overcooling.</b> Evaporator Blower, Condenser Blower and Compressor are running.	Failed Thermostat. Failed Relay.	Check Thermostat wire connections. Replace Thermostat. Replace Relay.
<b>Compressor cycling more than 10 cycles per hour.</b>	Short circuiting of air between A/C discharge and inlet openings.	Provide baffle in the enclosure separating A/C Outlet and inlet.
<b>Excess vibration.</b>	Defective motor in Blower. Defective wheel in Blower. Bad Compressor.	Replace motor. Replace wheel. Replace Compressor.



## X. Standard Warranty

KOOLTRONIC products are warranted to be free of defects in workmanship, materials and components. The following warranty periods apply from date of shipment:

- Air moving devices/components and hermetic system components: 1 year
- Spare parts, except filters: 90 days

The above warranty applies when the equipment is operated under the following conditions:

- Ambient temperature not in excess of 125°F (52°C) in normal atmosphere or as stated on product nameplate
- Voltage variation no greater than  $\pm 10\%$  from nameplate rating
- Frequency variation no greater than  $\pm 3\text{Hz}$  from nameplate rating
- Maximum cooling load no higher than air conditioner nameplate rating
- Waiting five minutes before restarting air conditioner after intentional or accidental shutoff
- Compliance to all other installation, maintenance and operating instructions, as supplied
- The purchaser assumes the responsibility of grounding the unit and installing it in accordance with local electrical and safety codes, as well as the National Electric Code (NEC) and OSHA

**KOOLTRONIC cannot assume responsibility for mis-application of its products or the erroneous selection of an inappropriate product by a non-authorized KOOLTRONIC representative. Our applications engineers will gladly assist in the selection of the proper product, provided all required details of the application are furnished.**

**THIS WARRANTY CONSTITUTES THE ENTIRE WARRANTY WITH RESPECT TO THE PRODUCT AND IS IN LIEU OF ALL OTHERS, EXPRESSED OR IMPLIED, INCLUDING ANY WARRANTY OF MERCHANTABILITY AND WARRANTY OF FITNESS FOR A PARTICULAR PURPOSE AND IN NO EVENT IS KOOLTRONIC RESPONSIBLE FOR ANY CONSEQUENTIAL DAMAGES OF ANY NATURE WHATSOEVER.**

### **RETURN AUTHORIZATION (RA) PROCEDURE**

- All returns require a Return Authorization number whether the return is for warranty or non-warranty repair, rotation of stock, damage or any other reason. Returns without an RA number will be refused.
- Customer must call KOOLTRONIC After Sale Kare (ASK), Pennington, New Jersey (609 • 466 • 3400) to obtain an RA number, or email ask@kooltronic.com.
- The following information is required when an RA is requested:
  - Original customer Purchase Order number and date
  - Date product was received by customer
  - Number of parts to be returned
  - Product description, model and serial number
  - Reason for return
  - Action requested
  - Contact name, telephone, FAX numbers and e-mail address
- Pack unit in a suitable container for shipment, preferably the

KOOLTRONIC assumes no liability beyond the repair or replacement of its own product. This Warranty does not cover:

- Labor or reimbursement of labor for evaluation, removal, installation, repair, or cost of any warranted part, unless authorized in writing by KOOLTRONIC
- Use of equipment for other than its designed purpose or operating conditions
- Operation in harsh, oily, corrosive or other abnormal environmental conditions, without the proper filtration, sealing, protective coatings and/or weather protection
- Damage to hermetic system resulting from continuous operation with dirty or clogged air filters or improper or negligent maintenance
- Use of refrigerant other than designated
- Customer modification or abuse
- Shipping damage or other accident (Claims for shipping damage are the responsibility of the customer. Timely claims must be filed by the customer with the freight carrier)
- Cracked or broken hermetic tubing, brazed joints or other internal damage caused by shipping or mishandling
- Damage caused by shipping units attached to an enclosure
- Any and all conditions resulting from noncompliance with the preceding operating conditions
- Returned freight must be paid by customer
- **This standard warranty does not apply to custom products. Consult your KOOLTRONIC representative for limitations**

original packaging if available. All Air Conditioners must be returned in an upright position properly secured to a pallet. **Improper packaging may void warranty claim.** If an Air Conditioner is received laying down or shipped via UPS or similar small parcel service the warranty will be void.

- Mark carton prominently with KOOLTRONIC's Return Authorization Number.
- Enclose all pertinent documents.
- Freight charges on all products returned to KOOLTRONIC shall be paid by the customer. Unauthorized collect shipments will be refused.
- If a unit is repaired under Warranty, KOOLTRONIC will pay the freight charges both ways within the Continental USA at KOOLTRONIC's negotiated rates. Warranty repaired units will be returned to customer at KOOLTRONIC expense only within the Continental USA.
- All authorized returns are subject to a restocking fee.