



***Keep This Manual
With Heat Exchanger***

*Find additional information on
this model at kooltronic.com or
use the Technical Documents
QR code below.*

*Technical
Documents*



***KNHX38, KNHX47 & KNHX59
SERIES NEMA 4/4X
AIR-TO-AIR
HEAT EXCHANGERS

OPERATOR'S MANUAL***

CAUTION

**BEFORE INSTALLING AND
USING THIS HEAT EXCHANGER,
IT IS IMPORTANT THAT THIS
MANUAL BE READ AND
UNDERSTOOD THOROUGHLY**



***KOOLTRONIC, INC.
30 Pennington-Hopewell Road
Pennington, NJ 08534
609•466-3400
FAX: 609•466-1114
www.kooltronic.com***

TABLE OF CONTENTS

		Page
I.	Introduction	2
II.	Incoming Inspection	3
III.	Product Handling	3
IV.	Product Identification and Nameplate	3
V.	Principles of Operation	4
VI.	Specific Model Data	4-6
	Technical Data	
	Major Component Replacements	
	Mounting	
	Drawings and Dimensions	
VII.	Maintenance	6
VIII.	Packing Procedure	7
IX.	Warranty	8

I. Introduction

Kooltronic TrimLine Heat Exchangers are designed for indoor applications with ambient temperatures from 50°F to 131°F and maximum allowable enclosure temperature of 160°F. These heat exchangers utilize a counterflow airstream, for maximum heat transfer efficiency in a closed-loop system, providing cooling within sealed electronic cabinets.

This Manual provides you with the necessary general information for properly installing and operating Kooltronic Heat Exchangers. Unit specific technical data and mounting instructions are presented later in the Manual.

II. Incoming Inspection

Kooltronic Heat Exchangers are designed, built, and packaged to withstand the shock and vibration normally associated with shipment by common carriers. Occasionally improper handling during shipping causes damage. Such handling could include unbanding of palletized shipments, failing to respect any carton handling instructions, falling off conveyors, excessive vibration, crushing, etc. Therefore, a thorough inspection should be done upon receipt of all shipments. Any carton tears, dents, scratches, or loose articles should be noted on the Freight Bill. Cartons should be opened promptly and the units inspected for CONCEALED DAMAGE.

An immediate claim **MUST** be filed with the freight carrier and an inspection requested. Retain all packing materials. Kooltronic cannot assume responsibility for Consignee's failure to file a timely freight claim.

III. Product Handling

- Do not attempt to operate your Kooltronic Heat Exchanger until you read and thoroughly understand this Manual.

CAUTION

Operate this unit only on the proper voltages and frequencies as noted on the nameplate.

- Before operating this unit, all electrical wiring must be checked to assure the proper connections.

IV. Product Identification and Nameplate

KOOLTRONIC
ENCLOSURE COOLING SOLUTIONS

Heat Exchanger

MODEL NO. ① SERIAL NO. ②

VOLTS. ③ FREQ. ③ PH. ③ AMPS ③ MAX. CABINET TEMP. °F ④

FILTER P/N ⑤ MAX. FUSE SIZE ③

UL **UL**
LISTED
SPECIAL PURPOSE
HEAT EXCHANGER

UNAUTHORIZED SERVICE OR MODIFICATION VIOLATES WARRANTY
ALL MOTORS ARE THERMALLY PROTECTED

THIS PRODUCT IS PROTECTED BY ONE OR MORE OF THE FOLLOWING
PATENTS: 3,019,965 3,120,166 3,211,360 3,559,728 3,807,493 AND
OTHER PATENTS PENDING

MANUFACTURED BY:
KOOLTRONIC, INC. PENNINGTON, NJ

- ① Model Number
- ② Serial Number
- ③ Electrical power characteristics
- ④ Maximum enclosure temperature
- ⑤ Filter Part Number

We recommend you copy this information from your unit.

① ② ⑤ When ordering parts, specify the Model Number and Serial Number.

③ Before operating, be sure that the power source matches these requirements.

④ Make sure that these parameters are met. Failure to do so may result in permanent damage to the unit

V. Principles of Operation

The main component of the heat exchangers is counterflow aluminum element through which heat transfer occurs.

Ambient blower draws ambient air from the bottom inlet through an aluminum mesh air filter, through the element and exhaust it through a discharge grill.

Cabinet blower draws cabinet air from the top inlet through the element and exhaust it through the bottom discharge into the cabinet.

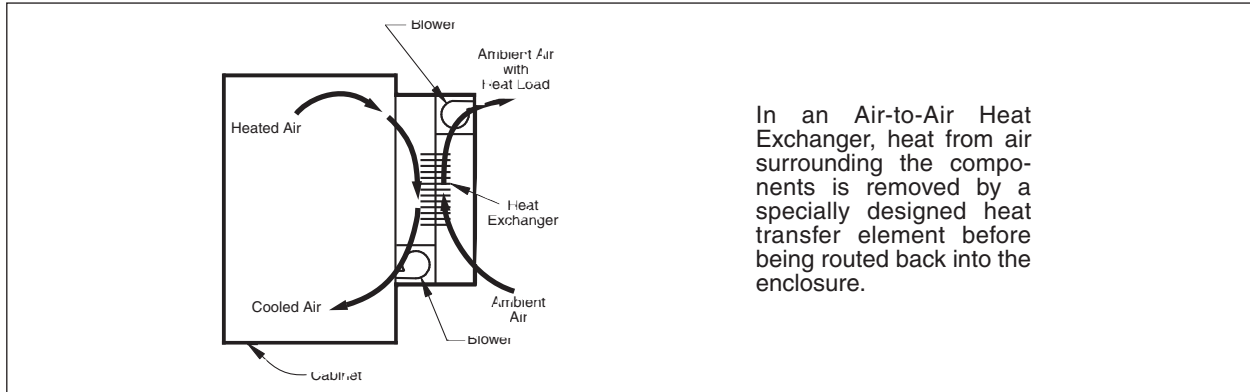

VI. Specific Model Data

Technical Data**

Model	Volts	Power		Maximum Allowable Temperature °F		Performance Watts/°F		Approx. Weight (lbs.)
		Amps	Watts	Enclosure	Ambient	Air In	Air Out	
KNHX38	115	3.00	340	160	131	44	88	115
KNHX38E	115	3.00	340	160	131	44	88	115
K2NHX38	230	2.10	440	160	131	46	92	115
K2NHX38E	230	2.10	440	160	131	46	92	115
KNHX47	115	3.00	340	160	131	54	108	135
KNHX47E	115	3.00	340	160	131	54	108	135
K2NHX47	230	2.10	440	160	131	56	112	135
K2NHX47E	230	2.10	440	160	131	56	112	135
KNHX59	115	4.50	400	160	131	65	130	170
KNHX59E	115	4.50	400	160	131	65	130	170
K2NHX59	230	3.30	660	160	131	65	130	170
K2NHX59E	230	3.30	660	160	131	65	130	170

**60 Hz. operation. For 50 Hz. operation, consult Kooltronic.

Major Component Replacements

	KNHX38 KNHX38E	KNHX47 KNHX47E	KNHX59 KNHX59E
Condenser Blower Assembly	6015-00-129	6015-00-129	8060-00-11
Condenser Blower Capacitor	0452-06	0452-06	0452-03
Condenser Blower Blower Motor	0261-08	0261-08	0261-149
Evaporator Blower Assembly	6015-00-129	6015-00-129	604559-00-36
Evaporator Blower Capacitor	0452-06	0452-06	0452-03
Evaporator Blower Blower Motor	0261-08	0261-08	0261-149
Filter	10871F	10871F	10871F

Above parts are for 115V units. For 230V, consult factory.

Mounting

Kooltronic Special Purpose Heat Exchangers have been engineered to be installed easily. These units use fully gasketed flanges to insure a seal between the heat exchanger and the cabinet. This seal is necessary to maintain the integrity of the closed loop system as well as the NEMA 4 rating.

Prior to mounting, refer to page 6 for general arrangement drawings showing dimensions and locations of mounting holes and cutouts. Prior to cutting or drilling, make sure that cutouts and mounting holes do not interfere with components inside of the cabinet. To avoid damaging your Heat Exchanger, please read the following information before installation.

1. Remove and discard (2) nuts and washers holding the Mounting Template and Assembly Bracket (M/TAB) to the Heat Exchanger. Remove M/TAB.
2. See page 6 for proper orientation. Place the M/TAB flush against the outside of the cabinet to locate cutouts and M/TAB mounting holes. **The minimum distance between lower end of the M/TAB to the ground is 12" for all KNHX units.**
3. The cutout for warm air return does not have to match the full opening on the M/TAB. You can locate your cutout anywhere within this opening, making the return air cutout from the cabinet as large as possible. Make the cold air supply cutout the same size as on the M/TAB.
4. Mount the M/TAB to the outside of the cabinet using all the 1/4-20 x 1/2" bolts, washers and nuts supplied by Kooltronic.
5. Route the power cord through the return air cutout of the cabinet. Mount the heat exchanger on the M/TAB by sliding the mounting studs, installed on the heat exchanger side panels, into the inclined slots of the M/TAB.
6. Carefully mark all mounting holes from the flanges of the heat exchanger to the cabinet wall. All holes in the heat exchanger flange must be used to maintain the NEMA 4 rating.
7. Remove the heat exchanger from the M/TAB and drill .218" dia. mounting holes in the cabinet. Do not attempt to drill mounting holes in the enclosure without first removing the heat exchanger. Drilling through the sealing gasket may damage it and remove the NEMA 4 rating.
8. Repeat actions, described in item "5" above.
9. Insert the stainless steel screws with seal washers supplied through holes in the mounting flanges and the cabinet wall. Install washers and nuts on each screw from inside of the cabinet and hand tighten. Tighten all nuts to a torque of 20 in.-lbs. going in a clockwise rotation starting from the top left corner. Retighten to a final torque of 34-40 in.-lbs. in the same rotation as previously used. The torque should be rechecked after the gasket has been allowed to set for 1 hr. and again after the heat exchanger has been run for 24 hrs. Check the flange gasket compression, after tightening all nuts - the gasket should be compressed by approximately 1/2 the gasket thickness (1/8").
10. After making sure that the source voltage and frequency are the same as shown on the unit nameplate, connect the heat exchanger's power cord to the power supply.

CAUTION

If the Heat Exchanger is mounted to the cabinet door you must be sure that the door hinges will support the additional weight of the Heat Exchanger. Also be certain that when the door is opened fully, the cabinet does not become unbalanced. The actual weight of the unit can be found in the performance specifications.

Drawings and Dimensions

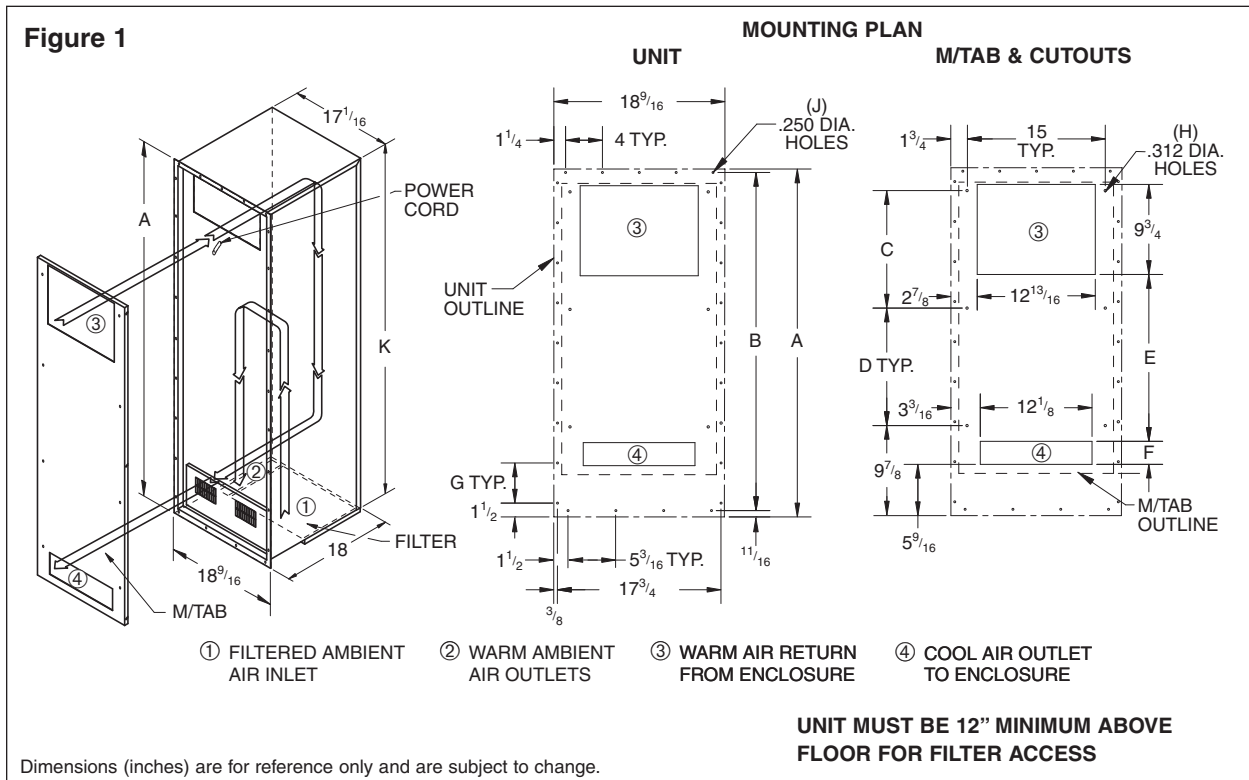

DIMENSIONS (inches)

Model	A	B	C	D	E	F	G	H	J	K
Series 38	37 ³ / ₄	36 ¹¹ / ₁₆	12 ³ / ₄	12 ³ / ₄	18 ¹ / ₈	2 ¹ / ₂	4 ¹¹ / ₃₂	6	27	37
Series 47	47	45 ¹⁵ / ₁₆	12 ¹ / ₄	11 ¹ / ₄	27 ³ / ₈	2 ¹ / ₂	4	8	33	46 ¹ / ₄
Series 59	59	58	16 ¹ / ₄	15 ¹ / ₄	38 ¹ / ₂	3 ³ / ₈	4	8	39	58 ¹ / ₄

VII. Maintenance

Kooltronic Air-Cooled Heat Exchangers are designed to require only routine cleaning of air filters and the heat exchanger element to assure unimpeded airflow through the heat exchanger element. It is not possible to recommend specific filter cleaning intervals since the level and the nature of air borne particulate matter differs widely with each installation. It is generally sufficient to remove and wash the reusable aluminum mesh air filter when the outer surface of these filters appear covered with a thin layer of dust or lint. Filter recoating adhesive is recommended. Appropriate disposable filters are available from Kooltronic.

If filter service is neglected or delayed, the heat exchanger will not perform at its design capacity. The first indication of excessively clogged air filter is usually a gradual increase of temperature within the equipment cabinet. Continued operation under these conditions will cause damage, shorten blower motor life and void the warranty.

CAUTION

Disconnect electric power from the Heat Exchanger before proceeding.

Filter Removal and Service

Kooltronic Heat Exchanger feature an easily removable inlet filter to facilitate necessary cleaning.

CAUTION

Do not operate the Heat Exchanger for extended periods of time with the filter removed. The heat exchanger element may become clogged with dust or lint from the ambient environment. A clogged heat exchanger element is not readily detected and will give the same reaction as clogged filter. A clean filter is the best protection.

- 1) Move the filter forward, using attached tab, to clear the near filter retainer. Pull the filter downward and toward you until the far side of the filter clears the far filter retainer.
- 2) After removal, the filter should be flushed under warm running water with the clean side up, driving contaminants out the dirty side of the filter. If the accumulated dirt is oily, washing in a detergent bath is recommended, followed by warm water rinse as above.
- 3) The filter may be sprayed with **Kooltronic A-16 Filter Recoating Adhesive** to trap fine airborne contaminants, or they can simply be dried and reinstalled as strainer type filters. **Recoating is recommended for the best results.**
- 4) Reinstall the filter: (a) Holding the tab, slide the filter into the near retainer, (b) press filter against the unit and (c) slide forward into far retainer.

VIII. Packing Procedure

- Keep Heat Exchanger in proper upright position.
- Pack Heat Exchanger in an appropriate carton (preferably original carton if possible), with adequate internal protective packaging, making sure carton is marked properly.
- For local controlled transportation, strap carton where possible, to a secure part of truck to prevent falling or sliding, minimizing vibration, etc.
- For common carrier shipment, band unit(s) securely to a pallet. Unpalletized shipment risks severe damage which voids the warranty.

