

***Keep This Manual
With Heat Exchanger***

*Find additional information on
this model at kooltronic.com or
use the Technical Documents
QR code below.*

*Technical
Documents*



***KPHE20 SERIES
WATER-TO-AIR
HEAT EXCHANGER

OPERATOR'S MANUAL***

CAUTION

**BEFORE INSTALLING AND
USING THIS HEAT EXCHANGER,
IT IS IMPORTANT THAT THIS
MANUAL BE READ AND
UNDERSTOOD THOROUGHLY**



***KOOLTRONIC, INC.
30 Pennington-Hopewell Road
Pennington, NJ 08534
609•466-3400
FAX: 609•466-1114
www.kooltronic.com***

TABLE OF CONTENTS

		Page
I.	Introduction	2
II.	Incoming Inspection	3
III.	Product Handling	3
IV.	Product Identification and Nameplate	3
V.	Principles of Operation	4
VI.	Specific Model Data	4-6
	Mounting	
	Drawings and Dimensions	
	Technical Data	
	Major Component Replacements	
	Accessories	
VII.	Maintenance	7
VIII.	Packing Procedure	7
IX.	Warranty	8

I. Introduction

Kooltronic Heat Exchangers are designed to provide a cool environment for your electronic or electrical components. There are models to fit virtually all sizes and shapes of electrical or electronic enclosures. Our “closed loop” design also ensures that your components will not be exposed to hot, dirty operating conditions.

This Manual provides you with the necessary general information for properly installing and operating Kooltronic Heat Exchangers. Unit specific technical data and mounting instructions are presented later in the Manual.

II. Incoming Inspection

Kooltronic Heat Exchangers are designed, built, and packaged to withstand the shock and vibration normally associated with shipment by common carriers. Occasionally improper handling during shipping causes damage. Such handling could include unbanding of palletized shipments, failing to respect any carton handling instructions, falling off conveyors, excessive vibration, crushing, etc. Therefore, a thorough inspection should be done upon receipt of all shipments. Any carton tears, dents, scratches, or loose articles should be noted on the Freight Bill. Cartons should be opened promptly and the units inspected for CONCEALED DAMAGE.

An immediate claim MUST be filed with the freight carrier and an inspection requested. Retain all packing materials. Kooltronic cannot assume responsibility for Consignee's failure to file a timely freight claim.

III. Product Handling

- Do not attempt to operate your Kooltronic Heat Exchanger until you read and thoroughly understand this Manual.

CAUTION

Operate this unit only on the proper voltages and frequencies as noted on the nameplate.

- Before operating this unit, all electrical wiring must be checked to assure the proper connections.

IV. Product Identification and Nameplate

KOOLTRONIC
ENCLOSURE COOLING SOLUTIONS

Heat Exchanger

MODEL NO. ①

SERIAL NO. ②

VOLTS. ③ FREQ. ③ PH. ③ AMPS ③ MAX. CABINET TEMP. °F ④

FILTER P/N ⑤ MAX. FUSE SIZE ③

UNAUTHORIZED SERVICE OR MODIFICATION VIOLATES WARRANTY
ALL MOTORS ARE THERMALLY PROTECTED

THIS PRODUCT IS PROTECTED BY ONE OR MORE OF THE FOLLOWING
PATENTS: 3,019,965 3,120,166 3,211,360 3,559,728 3,807,493 AND
OTHER PATENTS PENDING

MANUFACTURED BY:
KOOLTRONIC, INC. PENNINGTON, NJ

- ① Model Number
- ② Serial Number
- ③ Electrical power characteristics
- ④ Maximum ambient operating temperature

We recommend you copy this information from your unit.

- ① ② When ordering parts, specify the Model Number and Serial Number.
- ③ Before operating, be sure that the power source matches these requirements.
- ④ Make sure that these parameters are met. Failure to do so may result in permanent damage to the unit

V. Principles of Operation

If ambient air cannot be utilized directly as a cooling medium, another cost-effective method of cooling is a Water-to-Air system (below). Water is used to remove heat from the air circulated within the electronics enclosure.

Cooling water is circulated through a tube-and-fin coil. As the heat-laden air circulates through the coil, the heat is absorbed by the water and carried away, in a continuous process.

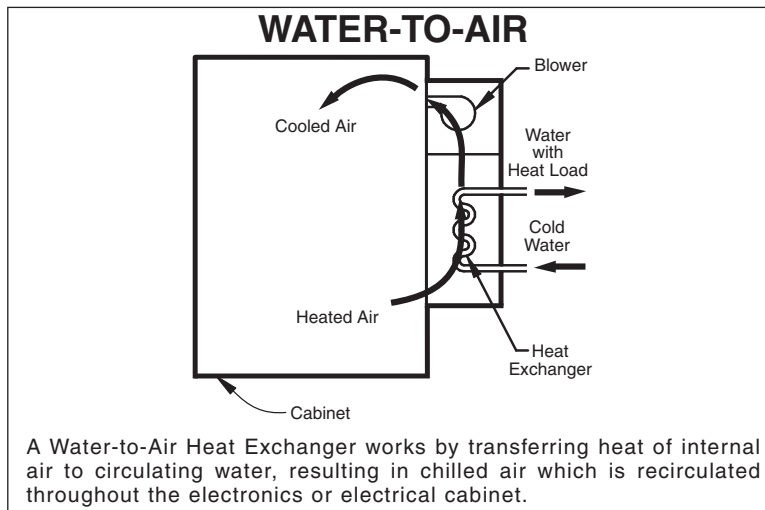
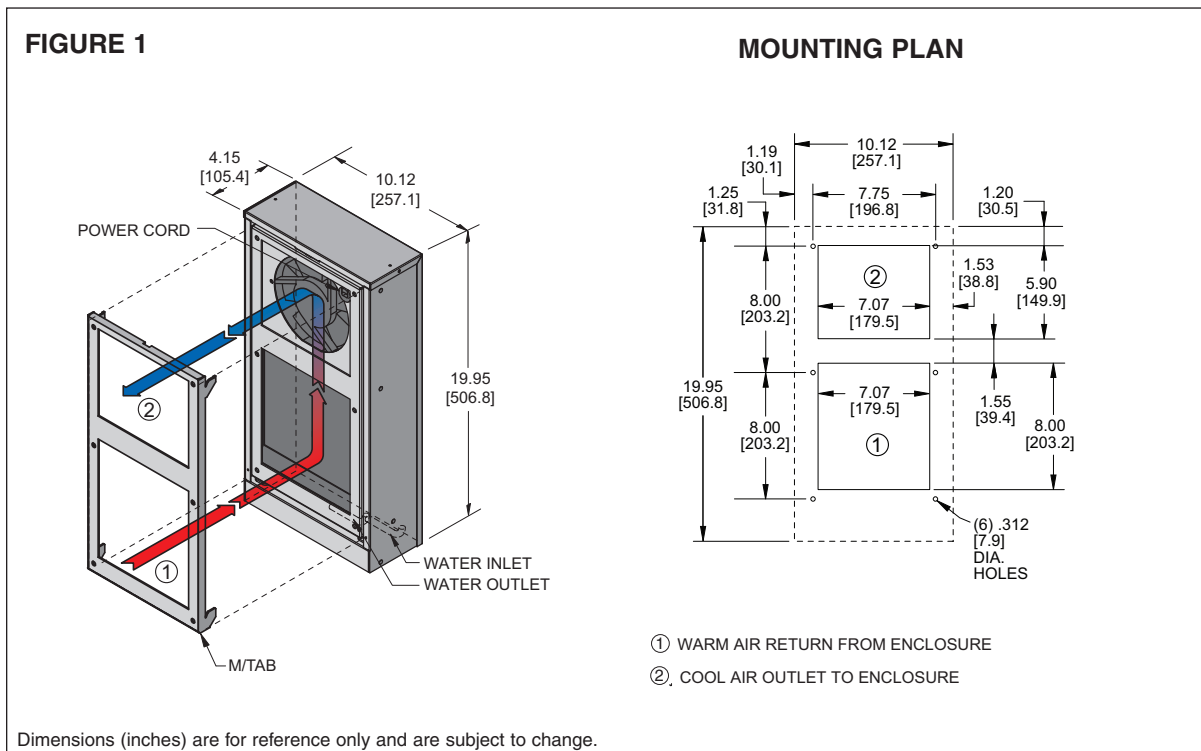

Figure 1

Water-to-Air systems are easy to install and usually require minimum maintenance. The water used must be reasonably clean and cold enough to ensure proper operation of the cooling system under the most severe anticipated conditions. In some cases, if sufficiently cold water is available, below-ambient-temperature cooling can be achieved.

VI. Specific Model Data

Mounting



Kooltronic Heat Exchangers have been engineered to be installed easily. To avoid damaging your Heat Exchanger, please read the following information before installation:

1. Loosen the two screws on the bottom holding the Mounting Template and Assembly Bracket (M/TAB) to the unit. Remove the M/TAB.
2. See Figure 1 for proper orientation. Place the M/TAB flush against the outside of the cabinet to locate cutouts and mounting holes.
3. **Make sure the cutouts don't interfere with components inside your cabinet.**
4. Mount the M/TAB to the outside of the cabinet using all the mounting hardware supplied by Kooltronic (1/4-20 screws/nuts/washers). Preferred positions: one in each corner and two near center on each side. NOTE: Make sure the screws are inserted with heads toward you. Tighten nuts securely.
5. Route the power cord through the top cut out in your cabinet. Mount the unit to the M/TAB by sliding the slots on the bulkhead into the hooks on the M/TAB. After unit is in place, tighten 2 screws at bottom of unit. These two screws will force the M/TAB into studs on side panel for a tight seal.
6. Attach overflow drain hose supplied to the drain exit at the bottom of the unit. This hose must not be elevated above the exit port. Improper mounting will impede the flow of condensate and may cause internal malfunctions.
7. Attach supply line to 3/8" O.D. copper tubing Inlet on bottom of unit.
8. Attach discharge line to 3/8" O.D. copper tubing Outlet on bottom of unit.

Technical Data

Model	Volts	Amps	Watts	Maximum Inlet Water Temp. °F	Performance		Approx. Weight (lbs.)
					Watts/°F		
					0.25gpm	0.5gpm	
KPHE20	115	0.30	33	85	20.5	21.5	15
K2PHE20	230	0.13	25	85	20.5	21.5	15

Note: The rating Watts/°F is the heat dissipation divided by temperature difference between maximum air temperature in enclosure and water temperature entering the heat exchanger.

Major Component Replacements

	<u>KPHE20</u>	<u>K2PHE20</u>
	<i>Part Number</i>	<i>Part Number</i>
Fan	0265-03	0265-06
Coil	0667-28	0667-28

NOTE: Part Numbers shown are for 60Hz/1Ø. For 50Hz consult Kooltronic.

Options

- Internal corrosion resistant coatings
- Other voltages and frequencies
- Special materials or finishes
- Special motors, line cords or connectors

VII. Maintenance

In general, very little maintenance or repair is required on Water-to-Air Heat Exchangers.

CAUTION

Disconnect electric power from the Heat Exchanger before servicing unit.

Blowers - Removable for Repair or Replacement

In Water-to-Air Heat Exchangers, powerful blowers are used. Each is carefully chosen to provide optimum airflow characteristics for component cooling as well as heat transfer within the unit.

Each of these air moving devices have been engineered and constructed to provide years of trouble-free operation and thus require no periodic maintenance.

In the case of air mover failure, blowers are easily removable with simple tools.

Replacement Blower Assemblies and Motors are generally readily available from Kooltronic stock.

Please see the listing of Major Component Replacements earlier in this Manual.

CAUTION

Do not handle or carry the blower by inserting fingers into the blower opening where wheels are located. This could cause a wheel misalignment problem and create an out-of-balance condition. Also, the sharp vanes could result in injury.

VIII. Packing Procedure

- Keep Heat Exchanger in proper upright position.
- Pack Heat Exchanger in an appropriate carton (preferably original carton if possible), with adequate internal protective packaging, making sure carton is marked properly.
- For local controlled transportation, strap carton where possible, to a secure part of truck to prevent falling or sliding, minimizing vibration, etc.
- For common carrier shipment, band unit(s) securely to a pallet. Unpalletized shipment risks severe damage which voids the warranty.

