



Installation Instructions

Model KA4C3.5H9R

with Serial Numbers up to and including G17A2183

Model K2A4C3.5H9R

with Serial Numbers up to and including D17A1221

Model KA4C3.5H10R

with Serial Numbers up to and including L14A3003

Model K2A4C3.5H10R

with Serial Numbers up to and including K15A3548

I. Introduction

These instructions provide you with the general information necessary for proper installation of the air conditioners.

CAUTION

BEFORE INSTALLING THE AIR CONDITIONER, IT IS IMPORTANT THAT THESE INSTRUCTIONS BE READ AND UNDERSTOOD THOROUGHLY

II. Incoming Inspection

Kooltronic Air Conditioners are designed, built and packaged to withstand the shock and vibration normally associated with shipment by common carriers. Occasionally improper handling during shipping causes damage. Such handling could include unbanding of palletized shipments, failing to respect "This Side Up" arrows, rough handling, falling off conveyors, excessive vibration, crushing, etc. Therefore, a thorough inspection should be done upon receipt of all shipments. Any carton tears, dents, scratches, loose articles or evidence of oil are signs of damage and should be noted on the Freight Bill. Cartons should be opened promptly and the units inspected for CONCEALED DAMAGE. Kooltronic Air Conditioners must be delivered in the proper mounting position to assure that damage to the compressor has not occurred during shipping. Any Kooltronic Air Conditioner that is delivered removed from the banded pallet, lying down or double stacked should be refused. An immediate claim MUST be filed with the freight carrier and an inspection requested. Retain all packing materials. Kooltronic cannot assume responsibility for Consignee's failure to file a timely freight claim.

III. Pre-Installation Testing

1. The unit must sit in an upright position at a minimum room temperature of 65°F to allow the system to warm up.
2. Refer to the identification label for proper electrical voltage and current requirements. Connect the power cord to a properly grounded and fused electrical supply, leaving electrical power to the unit turned off.
3. Note the factory thermostat setting which is 75°F to 80°F. Adjust the thermostat to its maximum setting.
4. If your unit is equipped with an on-off switch, move it to the on position. Turn the electrical power on. Verify that the evaporator blower or fan is running.
5. Adjust the thermostat to its minimum setting. The compressor should start. On units equipped with a short cycle protector, the compressor will have a delayed start of six (6) minutes from the time power is applied to the unit.
6. Verify that the condenser blower or fan is running. On units equipped with a low ambient kit, the start of the condenser fan or blower will be delayed until the system pressures rise.
7. Operate the air conditioner for approximately ten (10) minutes. During this period no unusual noise or vibration should be evident. Both the evaporator and condenser fans or blowers should be delivering air through their respective discharge ports. The cool air discharged should be less than 70°F when the room temperature is between 70°F and 80°F.
8. On units equipped with heaters, adjust both the cooling and heating thermostats to their maximum settings. Verify that the compressor and condenser fan or blower has stopped. Verify elevated discharge air temperature from the evaporator air discharge.
9. If your unit is equipped with an on-off switch, leave it in the on position. Return the cooling thermostat to its original setting. If the unit is equipped with a heater, return the heating thermostat to its original position.
10. Turn off the electrical power and disconnect the air conditioner from the power source.
11. If any cover plug was removed to adjust the unit, be sure to replace it in order to maintain the integrity of the closed-loop airflow system.

IV. Mounting

1. Rack-Mounted Air Conditioners for internal horizontal installation are equipped with EIA-Notched mounting flanges.
2. Refer to Mounting Plan for the location of all mounting flanges and cutouts.
3. Make sure the cutouts don't interfere with the components inside your cabinet.
4. Proper alignment of all air inlets and outlets is essential for optimum performance of the Air Conditioner.
5. Use all existing mounting holes to insure stability and a tight seal.
6. High strength mounting screws are recommended.
7. The external drain hose must not be elevated above the exit port. Improper mounting will impede the flow of condensate and may cause internal malfunctions.

CAUTION

Kooltronic Air Conditioners must be standing in their proper mounting position for a minimum of five (5) minutes prior to testing. Failure to follow this procedure will cause permanent damage to the compressor. To avoid compressor damage do not tip the unit more than 45° from its proper mounting position.

Kooltronic Air Conditioners must be operated in their proper mounting position. If attempts are made to operate a unit that is not in its designed mounting position, permanent compressor damage will occur. This action will void the warranty.

The weight of the unit is 95 lbs. Additional technical data can be found in the performance specifications in the Operator's Manual available online.

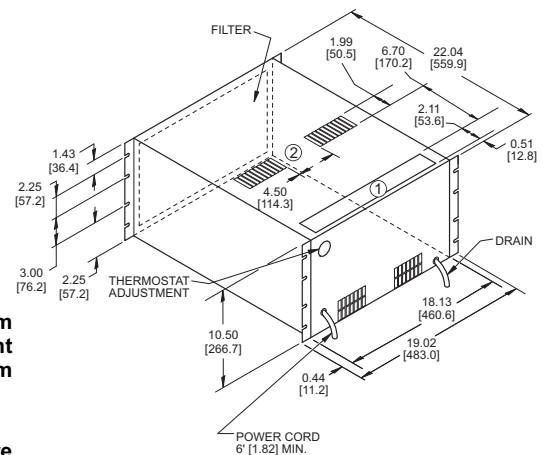

MOUNTING PLAN

- ① WARM AIR RETURN FROM ENCLOSURE
- ② COOL AIR OUTLET TO ENCLOSURE

Dimensions, inches [mm], are for reference only and are subject to change.



KOOLTRONIC, INC. 30 Pennington-Hopewell Road Pennington, NJ 08534

609•466-3400 FAX: 609•466-1114

kooltronic.com

900-090-39 (12/18)
(CDR: 20111)

Additional Information on this air conditioner can be found by visiting kooltronic.com and searching for the model number, or use the Technical Documents QR code below.

Technical Documents



V. Warranty You can register your warranty online by going to our homepage at kooltronic.com, under **Support**, or use the Warranty QR code below.

Kooltronic products are warranted to be free of defects in workmanship, materials and components. The following warranty periods apply from date of shipment:

- Air moving devices/components and hermetic system components: 1 year
- Spare parts, except filters: 90 days

The warranty applies when the equipment is operated under the following conditions:

- Ambient temperature not in excess of 125°F (52°C) in normal atmosphere or as stated on product nameplate
- Voltage variation no greater than $\pm 10\%$ from nameplate rating
- Frequency variation no greater than $\pm 3\text{Hz}$ from nameplate rating
- Maximum cooling load no higher than air conditioner nameplate rating
- Waiting five minutes before restarting air conditioner after intentional or accidental shutoff
- Compliance to all other installation, maintenance and operating instructions

The purchaser assumes the responsibility of grounding the unit and installing it in accordance with local electrical and safety codes, as well as the National Electric Code (NEC) and OSHA

KOOLTRONIC cannot assume responsibility for misapplication of its products or the erroneous selection of an inappropriate product by a non-authorized KOOLTRONIC representative. Our applications engineers will gladly assist in the selection of the proper product, provided all required details of the application are furnished.

KOOLTRONIC assumes no liability beyond the repair or replacement of its own product. This Warranty does not cover:

- Labor or reimbursement of labor for evaluation, removal, installation, repair or cost of any warranted part, unless authorized in writing by Kooltronic
- Use of equipment for other than its designed purpose or operating conditions
- Operation in harsh, oily, corrosive or other abnormal environmental conditions, without the proper filtration, sealing, protective coatings and/or weather protection
- Damage to hermetic system resulting from continuous operation with dirty or clogged air filters or improper or negligent maintenance
- Use of refrigerant other than designated
- Customer modification or abuse
- Shipping damage or other accident (Claims for shipping damage are the responsibility of the customer. Timely claims must be filed by the customer with the freight carrier)
- Cracked or broken hermetic tubing, brazed joints or other internal damage caused by shipping damage or mishandling
- Damage caused by shipping units attached to an enclosure
- Any and all conditions resulting from noncompliance with the preceding operating conditions
- Returned freight must be paid by customer
- This Standard Warranty does not apply to custom products. Consult your Kooltronic representative for limitations

THIS WARRANTY CONSTITUTES THE ENTIRE WARRANTY WITH RESPECT TO THE PRODUCT AND IS IN LIEU OF ALL OTHERS, EXPRESSED OR IMPLIED, INCLUDING ANY WARRANTY OF MERCHANTABILITY AND WARRANTY OF FITNESS FOR A PARTICULAR PURPOSE AND IN NO EVENT IS KOOLTRONIC RESPONSIBLE FOR ANY CONSEQUENTIAL DAMAGES OF ANY NATURE WHATSOEVER.

VI. Return Authorization (RA) Procedure

All returns require a Return Authorization number whether the return reason is for warranty or non-warranty repair, rotation of stock, damage or any other type. Returns without an RA number will be refused.

Customer must call Kooltronic After Sale Kare (ASK), Pennington, New Jersey (609•466•3400) to obtain an RA number, or email ask@kooltronic.com.

The following information is required when an RA is requested:

- Original customer Purchase Order number and date
- Date product was received by customer
- Number of parts to be returned
- Product description, model and serial number
- Reason for return
- Action requested
- Contact name, telephone, FAX numbers and e-mail address

Pack unit in a suitable container for shipment, preferably the original packaging if available. All Air Conditioners must be returned in an upright position properly secured to a pallet. Improper packaging may void warranty claim. If an Air Conditioner is received laying down or shipped UPS or similar small parcel service the warranty will be void.

Mark carton prominently with Kooltronic's Return Authorization Number.

Enclose all pertinent documents.

Freight charges on all products returned to Kooltronic shall be paid by the customer. Unauthorized collect shipments will be refused.

If a unit is repaired under Warranty, Kooltronic will pay the freight charges both ways within the Continental USA at Kooltronic's negotiated rates. Warranty repaired units will be returned to customer at Kooltronic expense only within the Continental USA.

All authorized returns are subject to a restocking fee.

Warranty Registration

