

GUARDIAN/GUARDIANX SERIES DP50 480 VOLT 3-PHASE NEMA 4 or 4X AIR CONDITIONERS

Model	NEMA Rating	UL/CUL Listed or Recognized	BTU/H Rating	95/95 Rating	Ambient Temp.				Volts	Hz	* Running Amps	Weight	
					Max. °F	Min. °F	Max. °C	Min. °C				lbs	kg
K3NA6C14DP50L	4	Listed	14000	13000	131	-20	55	-29	480	60	5.0	207	94
K3NA6C14DP50LV	4X	Listed	14000	13000	131	-20	55	-29	480	60	5.0	207	94

* Rating shown is for operation at maximum ambient temperature.

STANDARD FEATURES

- Baked Powder Finish (NEMA 4 models)
- Closed-Loop Cooling
- Condenser Blower Controller
- Epoxy-Coated Condenser Coils
- External junction box for permanent wiring connections
- Filters (2)
- Heavy-duty Steel Shell
- Internal Corrosion Protection (NEMA 4X)
- Low Temperature Control Thermostat
- NEMA 4 or 4X Rating Maintained (UL50)
- Phase Sequence/Phase Loss Detector/Under Voltage Monitor
- Stainless Steel Shell (NEMA 4X models)
- UL/CUL Listed
- Zero ODP Refrigerant

Find additional information on this model at kooltronic.com, or use the Technical Documents QR code below.

Technical Documents



ACCESSORIES AND OPTIONS

- Compressor Short Cycle Protector
- Enclosure Heater
- Filter Recoating Adhesive
- Lead-Lag Controller
- Remote Thermostat Relay
- Replace Filters
- Special paint finishes
- Temperature Alarm



NEMA TYPE 4 OR 4X MAINTAINED

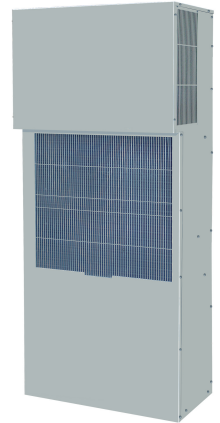

PERFORMANCE

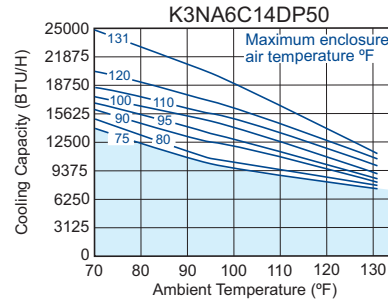

Operation within shaded area not recommended.

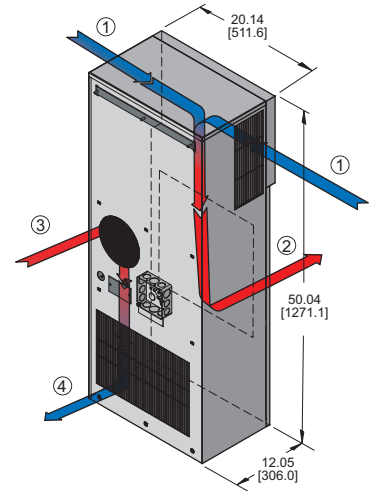

- ① CONDENSER AIR INLET (Ambient Air In)
- ② CONDENSER OUTLET (Warm Ambient Air Out)
- ③ WARM AIR RETURN FROM ENCLOSURE
- ④ COOL AIR OUTLET TO ENCLOSURE

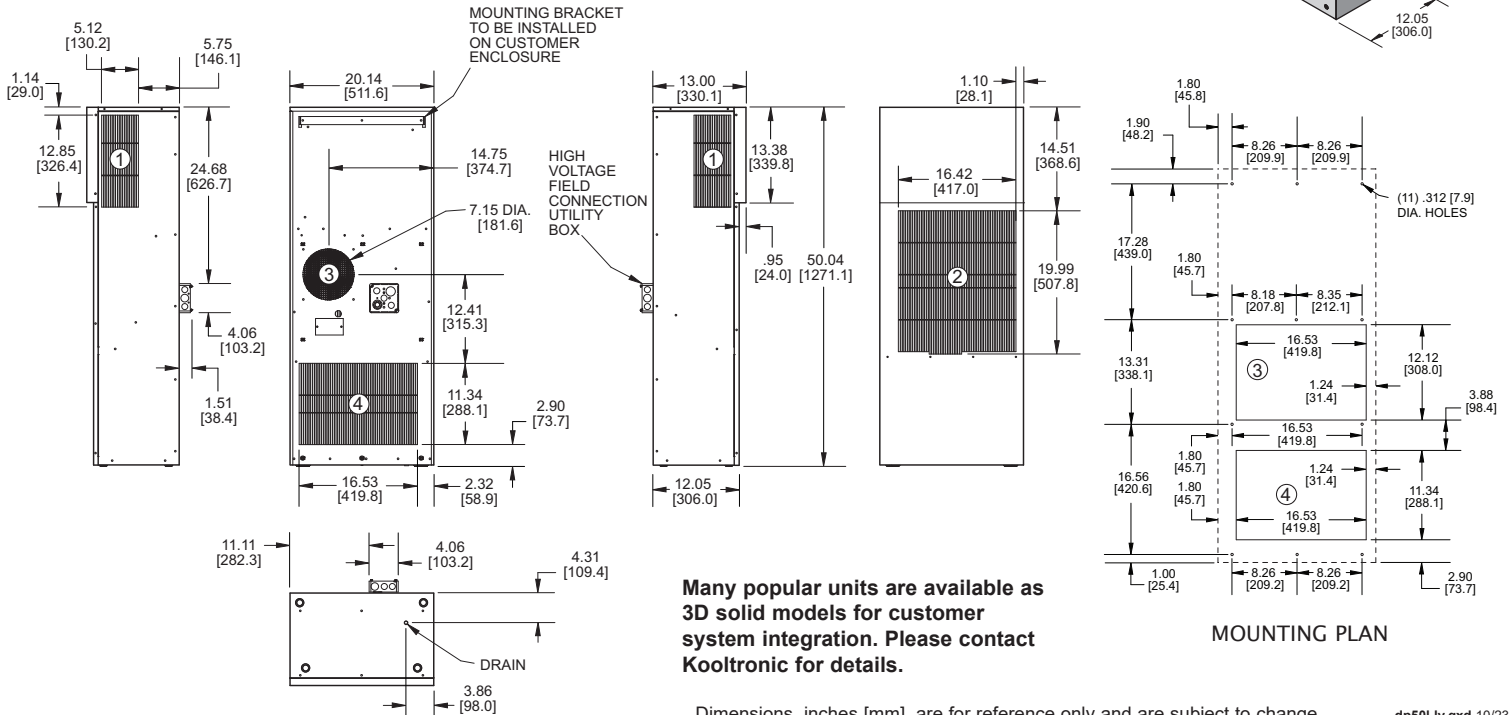

Many popular units are available as 3D solid models for customer system integration. Please contact Kooltronic for details.

MOUNTING PLAN

Dimensions, inches [mm], are for reference only and are subject to change.

dp50l-iv.qxd 10/23

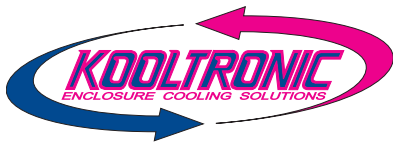

GUARDIAN/GUARDIANX SERIES DP50 480 VOLT 3-PHASE NEMA 4 or 4X AIR CONDITIONERS

DESCRIPTION

The **Guardian/GuardianX 480 Volt** Indoor/Outdoor Air Conditioners are designed specifically for **NEMA 4** or **4X** enclosure applications that require washdown or are subject to outdoor storm conditions. All **Guardian** models have a **NEMA 4** Rating. The **GuardianX**, with the **NEMA 4X** Rating, is offered with a Stainless Steel Shell and Internal Corrosion Protection. These Air Conditioners have been engineered to operate under the most demanding industrial applications. The components used in these models have been specially designed and tested to maintain cooling efficiency in temperature controlled enclosures in bottling plants, the automotive industry and other commercial/manufacturing applications.

With Epoxy-coated condenser coils and tubing, the closed-loop cooling system of the **Guardian/GuardianX 480 Volt Series** offers added security by providing an operating environment safe from harsh ambient conditions.

The features engineered into all of the **Guardian/GuardianX 480 Volt Series** models make them a tamper-resistant choice for external applications. Combined with a NEMA 4 Rating, with all models UL/CUL Listed, the **Guardian Series** is an excellent choice for telecommunications or other outdoor cabinet applications.

STANDARD FEATURES

BAKED POWDER FINISH: Durable, baked-on powder finish is standard. Other finishes are available.

CLOSED-LOOP COOLING: The enclosure interior airflow system is isolated from the ambient airflow system. Ambient air can not invade the cool, dehumidified sensitive component compartment.

CONDENSER BLOWER CONTROLLER: A thermostatic temperature sensor installed in the refrigerant liquid line, controlling the condenser fan.

EPOXY-COATED CONDENSER COILS: Condenser Coils in the **Guardian Series** models are Epoxy-Coated. This coating will withstand 1000 hours of salt spray per the ASTM B 117 test method. **NOTE:** Severe operational environments such as waste water treatment and salt spray are likely to cause corrosion failure over a period of time regardless of coating. **Warranty:** Corrosive conditions may effect the warranty coverage. Consult factory for warranty limitations in corrosive environments.

GASKETING: All units are fully gasketed for tight, leakproof installation, in compliance with the NEMA 4 Enclosure Rating.

HEAVY-DUTY STEEL SHELL: Precision-engineered heavy gauge steel construction of all shells and blowers insures Air Conditioners will stand up under tough applications.

INSULATION: All cold components, lines and the evaporator compartment are insulated with high-performance insulation for maximum efficiency.

LOW TEMPERATURE CONTROL THERMOSTAT: Thermostatic Low Temperature Control prevents over-cooling and provides energy-efficient operation.

POWER: 480 Volt.

QUALITY ASSURANCE: Refrigeration system components are kept sealed until charged with refrigerant; all brazed joints are thoroughly leak-tested; each unit is functionally tested before shipment.

REFRIGERANT: R410A, an HFC Refrigerant having zero ozone depleting potential, is used in the **Guardian Series DP50L** Air Conditioners.

UL/CUL LISTED: The **Guardian/GuardianX DP50L** is UL/CUL Listed.

ACCESSORIES AND OPTIONS*

TEMPERATURE ALARM: A thermostat is mounted inside the cabinet and attached to a sensor in the warm air return. When the air temperature increases to the set point, a signal is sent to a terminal block. User-installed wiring from the terminal block to local and/or remote warning devices (*light, bell, siren, etc.*) can be for normally open or closed operation.

ENCLOSURE HEATER: Fin strip heater, installed singly, used to maintain internal enclosure temperature, under cold operating conditions.

FILTER RECOATING ADHESIVE: This compound is a superior product for recoating filters after washing. The adhesives penetrate dirt layers to keep the filter surface tacky for longer effective performance between washings.

INTERNAL CORROSION PROTECTION: An air cured coating is sprayed on copper lines and brazed joints on the condenser side, providing a degree of protection from corrosive environments. This coating will withstand 1000 hours of salt spray per the ASTM B 117 test method. Also see Stainless Steel Cabinet or Integrity NEMA 4/4X Air Conditioners. **NOTE:** Severe operational environments such as waste water treatment and salt spray are likely to cause corrosion failure over a period of time regardless of coating. **Warranty:** Corrosive conditions may effect the warranty coverage. Consult factory for warranty limitations in corrosive environments. **NOTE:** For additional corrosion protection options, contact factory. Internal Corrosion Protection and Stainless Steel Shell are necessary in order to maintain **NEMA 4X** Rating for **GuardianX DP50**.

REPLACEMENT FILTER: Filter consisting of a multi-layer grid of sturdy corrugated aluminum, securely held in a one-piece aluminum frame. The DP50L filter Part No. is 13658F (13.63" x 5.88" x 0.34" [346.2mm x 149.3mm x 8.6mm]). The **Guardian Series DP50L** uses two filters.

COMPRESSOR SHORT CYCLE PROTECTOR: Protects the compressor from possible damage due to harmful short cycling.

STAINLESS STEEL SHELL: For applications in corrosive or other hostile environments where chemical/moisture combinations are present. Stainless Steel Shell and Internal Corrosion Protection are necessary in order to maintain **NEMA 4X** Rating for **GuardianX DP50**.

TEMPERATURE ALARM: A thermostat is mounted inside the cabinet and attached to a sensor in the warm air return. When the air temperature increases to the set point, a signal is sent to a terminal block. User-installed wiring from the terminal block to local and/or remote warning devices (*light, bell, siren, etc.*) can be for normally open or closed operation.

Special paint finishes*

*Contact KOOLTRONIC for more information.

