

THIS DOCUMENT IS THE PROPERTY OF KOOLTRONIC, INC. AND CONTAINS PROPRIETARY AND CONFIDENTIAL INFORMATION WHICH MUST NOT BE DUPLICATED, USED OR DISCLOSED TO OTHERS, EXCEPT AS EXPRESSLY AUTHORIZED IN WRITING BY KOOLTRONIC, INC.

REVISIONS				
SYM	NOTICE	DESCRIPTION	DATE	APPROVED
-	ER 11/058	NEW DRAWING RELEASE	10/18/11	JS

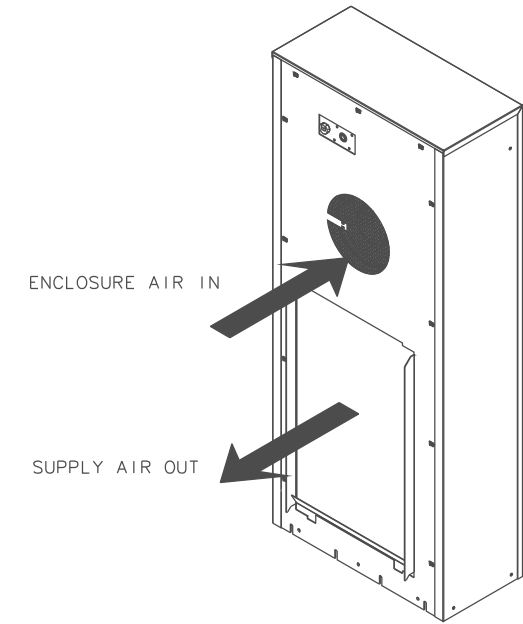

(\*W\* OPTION)  
THERMOSTAT  
ACCESS

(\*B\* & \*D\* OPTION)  
THERMOSTAT ACCESS

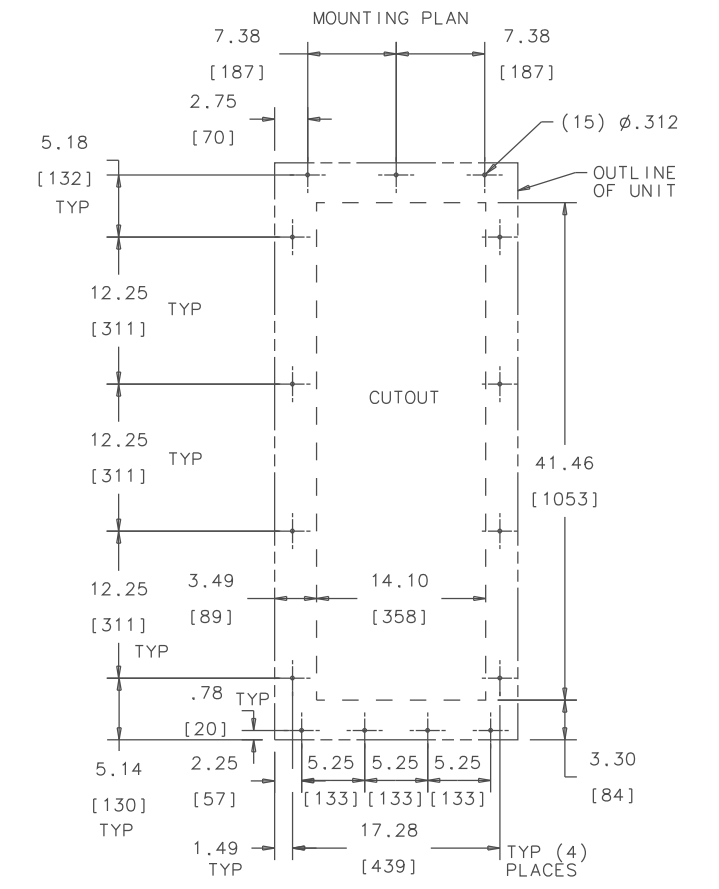
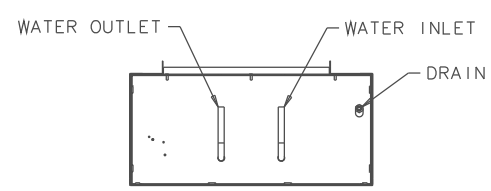
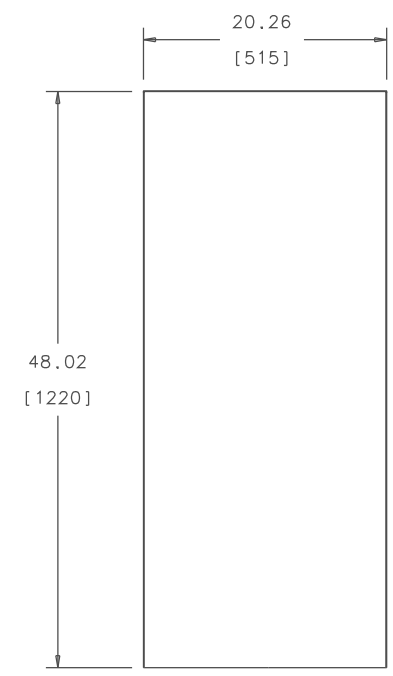
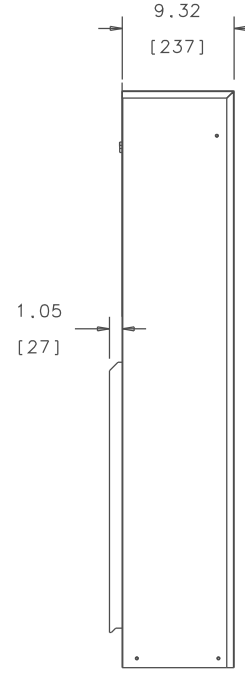
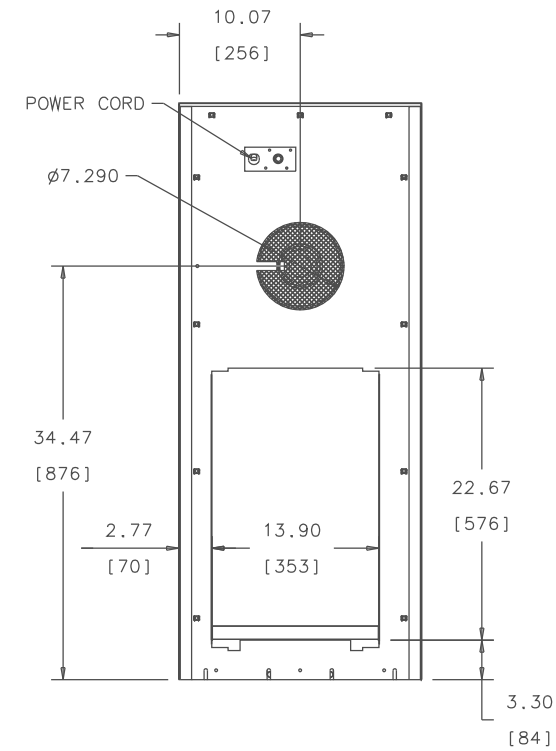
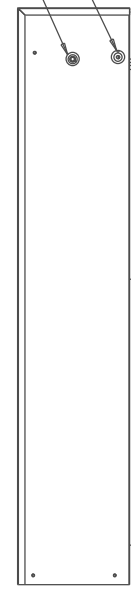

ALL DIMENSIONS ARE IN INCHES. DIMENSIONS DESIGNATED MM ARE IN MILLIMETERS.			 PENNINGTON, NJ USA	
UNLESS OTHERWISE SPECIFIED TOLERANCES NON-ACCUMULATIVE		DRAWN JERRY STEDNICK	DATE 8/22/11	
TOL. ON	INCHES	CHECKED Steve Schmierer	9/29/12	
.xx	± .02	ENG.	6/4/12	
.xxx	± .010	RON KAUFMAN	MFG. ENG.	
ANGULAR	± 1/2 °			
MATERIAL		TITLE GENERAL ARRANGMENT		
UNIT	K_NHE48	APPROVED Joe M/Bruce K	6/4/12	CODE IDENT. NO. 06223 SIZE D DWG. NO. GA710048A SCALE 1/25=1 REV -
			SHEET 1 OF 1	