

NP28 TRIMLINE AIR-COOLED PANEL-MOUNTED AIR CONDITIONERS

Legacy products are no longer in normal production. Consult factory for availability. Recommended replacement: See *Guardian/GuardianX* or *SlimKool Series*.

TECHNICAL DATA



Model	NEMA Rating	UL/CUL Listed or Recognized	BTU/H Capacity	95/95 Rating BTU/H	Ambient Temp		Volts	Hz	Running Amps	Fuse Amps	Approx. Weight	
					°F	°C					lbs	kg
KA6C4NP28L	12	Listed	4000	2823	120/50	49/10	115/110	60/50	8.0/8.0	15	85	39

Rating shown is for operation at maximum ambient temperature.

STANDARD FEATURES

- Baked Powder Finish
- Built-in Condensate Evaporator
- CFC-Free Refrigerant
- Closed-Loop Cooling
- Compressor Short Cycle Protector
- Epoxy-Coated Coils
- Filter
- Low Ambient Kit
- NEMA 12 Rating Maintained (UL50)
- Programmable Temperature Alarm
- Programmable Thermostat
- UL/CUL Listed

ACCESSORIES AND OPTIONS

- Filter Recoating Adhesive
- Internal Corrosion Protection
- Lifting Eyes
- Remote Monitoring
- Remote Thermostat Relay
- Replacement Filters
- Special controls or indicators
- Special materials or finishes
- Special motors, line cords, or connectors
- Stainless or Aluminum Shell



PERFORMANCE

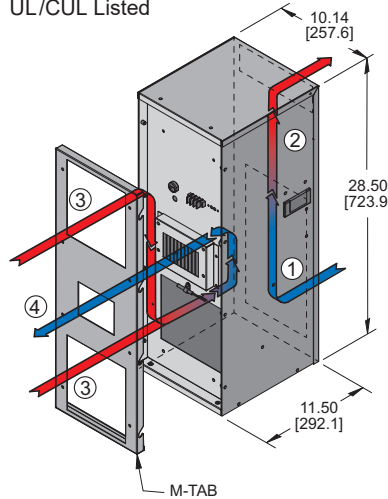
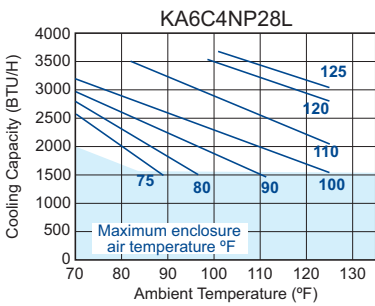

- ① CONDENSER AIR INLET (Ambient Air In)
- ② CONDENSER OUTLET (Warm Ambient Air Out)
- ③ WARM AIR RETURN FROM ENCLOSURE
- ④ COOL AIR OUTLET TO ENCLOSURE

Find additional information on this model at kooltronic.com, or use the Technical Documents QR code below.

Technical Documents

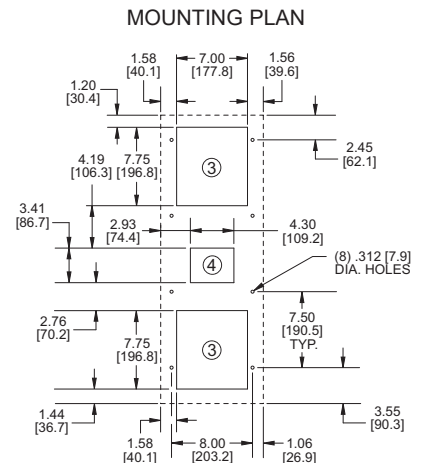
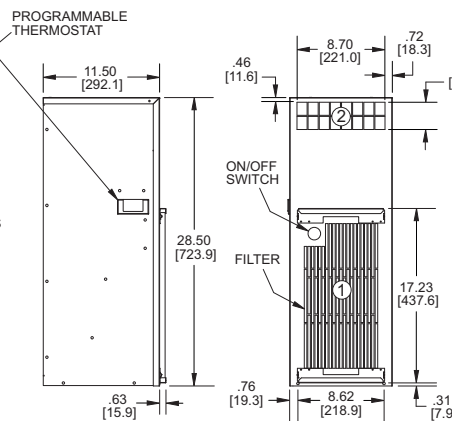
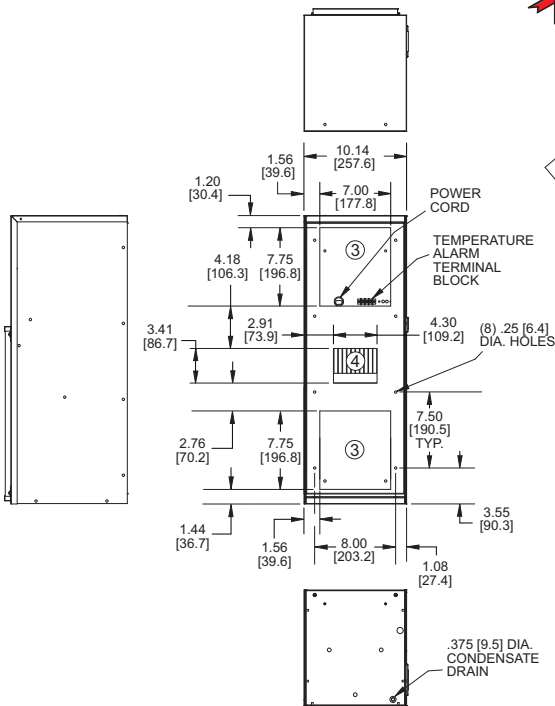

Many popular units are available as 3D solid models for customer system integration. Please contact Kooltronic for details.

Dimensions, inches [mm], are for reference only and subject to change.

np28.qxd (10/23) (CDR: 20532)

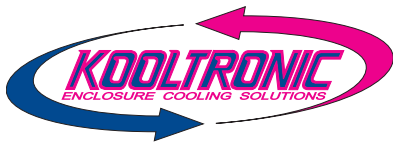

NP28 TRIMLINE AIR-COOLED PANEL-MOUNTED AIR CONDITIONERS

DESCRIPTION

The **TrimLine NP28 Series** consists of compact models with a capacity of 4,000 BTU/H. This series is designed with a minimum width to take up less cabinet space on the exterior panel or door.

Corrosive environments require special internal and external protective features. Also see Guardian/GuardianX and SlimKool NEMA 4/4X Series.

For extreme ambient temperatures and/or severely contaminated environments, the use of **TrimLine** or other **Water-Cooled Air Conditioners** is recommended.

KOOLTRONIC also designs and manufactures a variety of Air Conditioners to meet *unique* specifications. We invite your inquiries about our modification and custom-design capabilities.

FEATURES AND BENEFITS (STANDARD)

All models UL/CUL Listed, a standard of safety.

Built-in condensate evaporator eliminates the need for a drain (normal operation*).

CFC-free refrigerant provides a zero ozone depletion potential.

Closed-loop cooling provides stable temperature control while excluding dust and humidity from the electrical enclosure.

Compressor short-cycling protection extends compressor life.

Condenser impeller cycling provides stable capacity and temperature control.

Condenser filtration to maintain peak thermal performance extends compressor life.

Low Ambient Kit maintains sufficient operating pressures when ambient temperatures drop below 50°F [10°C].

NEMA 12 rating for compatibility with listed electrical enclosures.

Programmable temperature alarm to alert if early action required.

Programmable thermostat capable of remote monitoring and control.

Both evaporator and condenser coils are epoxy coated, prolonging unit life.

* May not be adequate in extremely high humidity with open or leaky enclosure. Overflow condensate drain fitting and hose are included.

FEATURES AND BENEFITS (OPTIONAL)*

Aluminum Shell if light weight and/or compatibility with aluminum enclosures is required.

Enclosure heater eliminates damaging condensation, increasing reliability of electrical enclosure components.

Mounting adapter plates are offered to replace another manufacturer's unit.

Remote monitoring provides temperature data for warning of early action required.

Remote thermostat relay for control by a user-supplied control system.

Stainless Steel Shell for applications in corrosive or other hostile environments.

Special paint finishes.

*Contact KOOLTRONIC for more information.

REPLACEMENT FILTERS

The NP28 filter Part No. 8751F (16.63" x 8".38 x 0.50" [422mm x 213mm x 13mm])

