

# H9 SERIES HORIZONTAL RACK-MOUNTED AIR-COOLED AIR CONDITIONERS

KA4C3.5H9R w/ s/n above D18A1263

K2A4C3.5H9R w/ s/n above D17A1221

## TECHNICAL DATA

Model	UL/CUR Listed or Recognized	95/95 Capacity BTU/H	Ambient Temp. Rating		Volts	Hz	Running Amps	Fuse Size (Amps)	Approx. Weight	
			°F	°C					lbs.	kg.
KA4C3.5H9R	Recognized	3500	3516	120/50	49/10	115/100	60/50	10.0	15	95 44
K2A4C3.5H9R	Recognized	3500	3137	125/50	52/10	230/200	60/50	5.1	15	95 44

Rating shown is for operation at maximum ambient temperature.

## STANDARD FEATURES

- Baked Powder Finish
- Built-in Condensate Evaporator
- CFC-Free Refrigerant
- Closed-Loop Cooling
- Compressor Short Cycle Protector
- Filter
- Low Ambient Kit
- Programmable Temperature Alarm
- Programmable Thermostat
- UL/CUR Recognized

## ACCESSORIES AND OPTIONS

- Filter Recoating Adhesive
- Internal Corrosion Protection
- Lifting Eyes
- Remote Monitoring
- Remote Thermostat Relay
- Replacement Filters
- Special controls or indicators
- Special materials or finishes
- Special motors, line cords or connectors



## PERFORMANCE

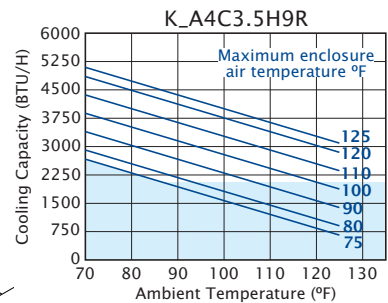

Operation within shaded areas not recommended.

Find additional information on this model at [kooltronic.com](http://kooltronic.com), or use the Technical Documents QR code below.



Technical Documents

H9

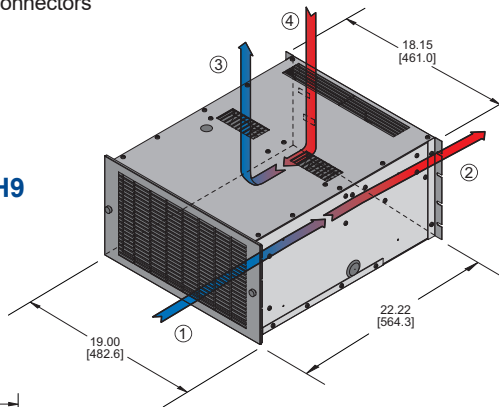

- ① FILTERED CONDENSER AIR INLET (Ambient Air In)
- ② CONDENSER OUTLET (Warm Ambient Air Out)
- ③ WARM AIR RETURN FROM ENCLOSURE
- ④ COOL AIR OUTLET TO ENCLOSURE

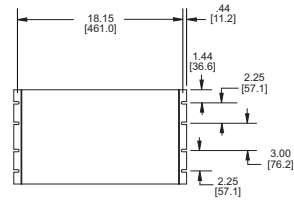
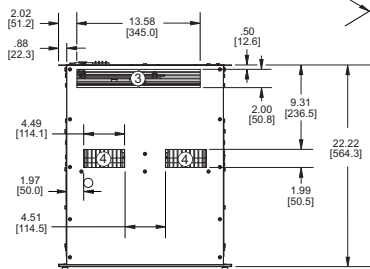

MOUNTING PLAN

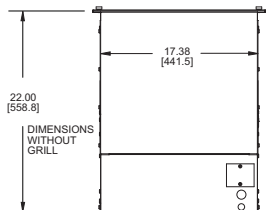
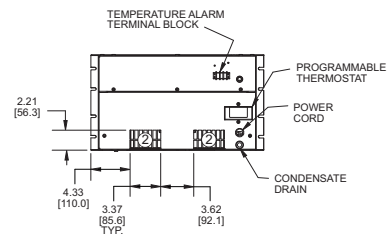
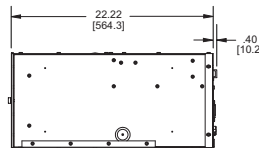
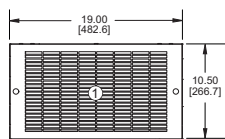
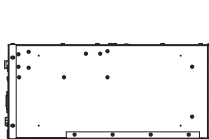

Many popular units are available as 3D solid models for customer system integration. Please contact Kooltronic for details.

Dimensions, inches [mm], are for reference only and subject to change.

h9.qxd (10/23) (CDR: 20532)

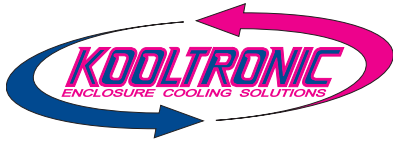

## H9 SERIES HORIZONTAL RACK-MOUNTED AIR-COOLED AIR CONDITIONERS

KA4C3.5H9R w/ s/n above D18A1263

K2A4C3.5H9R w/ s/n above D17A1221

### DESCRIPTION

KOOLTRONIC **H9 Air-Cooled Rack-Mounted Air Conditioners** are particularly suited for applications where internal horizontal mounting is preferred over external panel, door or top mounting.

Air-cooled models are typically mounted internally at either the top or bottom of the cabinet.

KOOLTRONIC **Rack-Mounted Air Conditioners** all include EIA-notched flanges. Air-cooled models are provided with attractive 19-inch wide stainless steel grilles and knurled captive fasteners for easy removal. Grille area is 65% open. If preferred, side rails can be supplied.

Outdoor or corrosive environments require weather protection and/or special internal and external protective features.

For extreme ambient temperatures and/or severely contaminated environments, the use of **Water-Cooled Air Conditioners** is recommended.

**KOOLTRONIC also designs and manufactures a variety of Air Conditioners to meet unique specifications. We invite your inquiries about our modification and custom-design capabilities**

### FEATURES AND BENEFITS (STANDARD)

All models UL/CUR Recognized.

Built-in condensate evaporator eliminates the need for a drain (normal operation\*).

CFC-free refrigerant is used in all H9 Air Conditioners.

Closed-loop cooling provides stable temperature control while excluding dust and humidity from the electrical enclosure.

Compressor short-cycling protection extends compressor life.

Low Ambient Kit maintains sufficient operating pressures when ambient temperatures drop below 50°F [10°C].

Programmable temperature alarm to alert if early action required.

Programmable thermostat capable of remote monitoring and control.

\* May not be adequate in extremely high humidity with open or leaky enclosure. Overflow condensate drain fitting and hose are included.

### FEATURES AND BENEFITS (OPTIONAL)\*

Internal corrosion protection to increase reliability in hostile environments.

Remote monitoring provides temperature data for warning of early action required. (Optional Feature on models with a Programmable Thermostat).

Remote thermostat relay for control by a user-supplied control system.

Special paint finishes.

\*Contact KOOLTRONIC for more information.

### REPLACEMENT FILTERS

The H9/H10 Filter Part No. is 1175F (16.63" x 9.63" x 0.50" [422mm x 244mm x 13mm])

