

HORIZONTAL SUPER-MINI AIR-COOLED TOP-MOUNTED AIR CONDITIONERS

with Serial Numbers L17A3868 and above

TECHNICAL DATA

Model	UL/CUR Listed or Recognized	95/95 BTU/H Capacity	Rating BTU/H	Ambient Temp.		Volts	Hz	Running Amps	Fuse Size (Amps)	Approx. Weight lbs. kg.
				°F Max./Min	°C Max./Min					
KA4C2.5HSR	Recognized	2500	2085	125/50	52/10	115/100	60/50	7.4	15	58 27
K2A4C2.5HSR	Recognized	2500	2356	125/50	52/10	230/200	60/50	3.0	15	58 27

Rating shown is for operation at maximum ambient temperature.



STANDARD FEATURES

- Baked Powder Finish
- Built-in Condensate Evaporator
- CFC-Free Refrigerant
- Closed-Loop Cooling
- Compressor Short Cycle Protector
- Filter
- Low Ambient Kit
- NEMA 12 Rating Maintained (UL50)
- Programmable Temperature Alarm
- Programmable Thermostat
- UL/CUR Recognized

ACCESSORIES AND OPTIONS

- Filter Recoating Adhesive
- Internal Corrosion Protection
- Lead-Lag Controller
- Lifting Eyes
- Remote Monitoring
- Remote Thermostat Relay
- Replacement Filters
- Special controls or indicators
- Special materials or finishes
- Special motors, line cords, or connectors
- Stainless or Aluminum Shell



NEMA TYPE 12 MAINTAINED

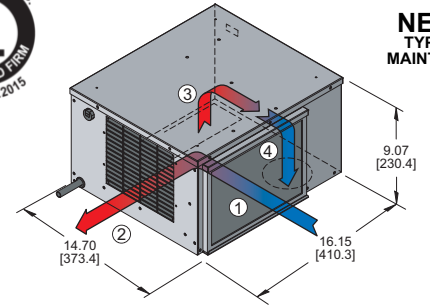

PERFORMANCE

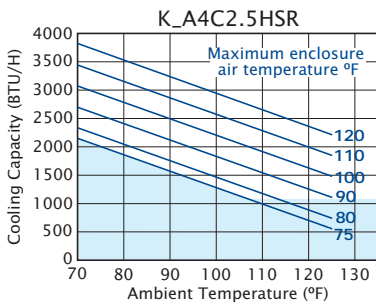

Operation within shaded area not recommended.

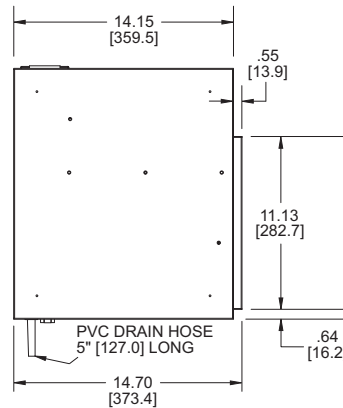

MOUNTING PLAN

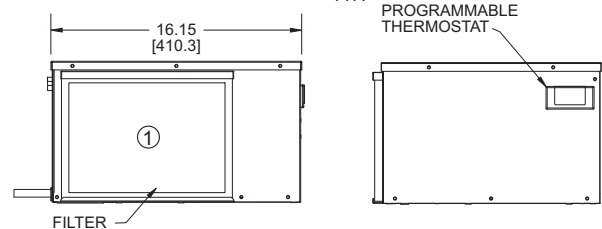
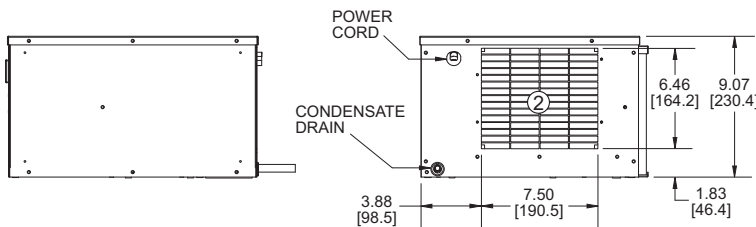
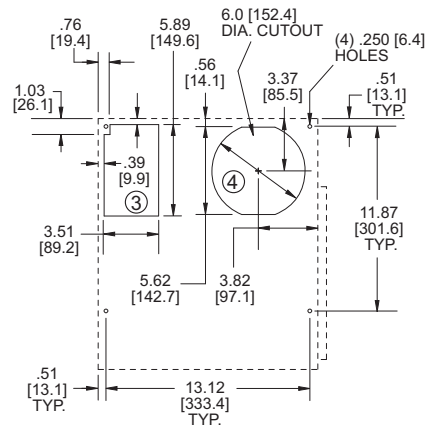

- FILTERED CONDENSER AIR INLET (Ambient Air In)
- CONDENSER OUTLET (Warm Ambient Air Out)
- WARM AIR RETURN FROM ENCLOSURE
- COOL AIR OUTLET TO ENCLOSURE

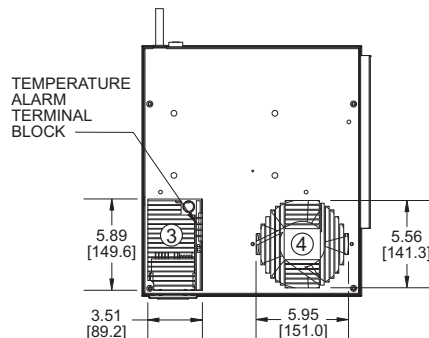

Find additional information on this model at kooltronic.com, or use the Technical Documents QR code below.

Technical Documents



Many popular units are available as 3D solid models for customer system integration. Please contact Kooltronic for details.

Dimensions, inches [mm], are for reference only and subject to change.

hzsmmini.qxd (12/2/19) (CDR: 20293)

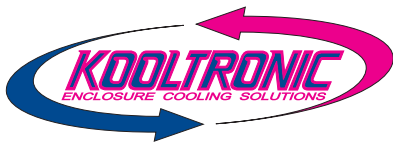

HORIZONTAL SUPER-MINI AIR-COOLED TOP-MOUNTED AIR CONDITIONERS

with Serial Numbers L17A3868 and above

DESCRIPTION

KOOLTRONIC *Horizontal Super-MiniTop-Mounted Air Conditioners* provide a full range of cooling capacities where space or other limitations prevent panel or internal rack mounting.

The low profile *Horizontal Super-Mini* is recommended for lower to moderate-demand cooling applications in smaller enclosures. They feature specially designed, heavy-duty centrifugal fans to force the cooling air throughout the enclosure.

Outdoor or corrosive environments require weather protection and/or special internal and external protective features.

For extreme ambient temperatures and/or severely contaminated environments, the use of *Water-Cooled Air Conditioners* is recommended.

KOOLTRONIC also designs and manufactures a variety of Air Conditioners to meet *unique* specifications. We invite your inquiries about our modification and custom-design capabilities.

FEATURES AND BENEFITS (STANDARD)

All models UL/CUR Recognized.

Built-in condensate evaporator eliminates the need for a drain (normal operation*).

CFC-free refrigerant provides a zero ozone depletion potential.

Closed-loop cooling provides stable temperature control while excluding dust and humidity from the electrical enclosure.

Low Ambient Kit maintains sufficient operating pressures when ambient temperatures drop below 50°F [10°C].

NEMA 12 rating for compatibility with listed electrical enclosures.

Programmable temperature alarm to alert if early action required.

Programmable thermostat capable of remote monitoring and control.

* May not be adequate in extremely high humidity with open or leaky enclosure. Overflow condensate drain fitting and hose are included.

FEATURES AND BENEFITS (OPTIONAL)*

Aluminum Shell if light weight and/or compatibility with aluminum enclosures is required.

Enclosure heater eliminates damaging condensation, increasing reliability of electrical enclosure components.

Lead-lag control for two air conditioners provides for capacity control, and alternates usage, increasing reliability.

Remote monitoring provides temperature data for warning of early action required.

Remote thermostat relay for control by a user-supplied control system.

Stainless Steel Shell for applications in corrosive or other hostile environments.

Special paint finishes.

*Contact KOOLTRONIC for more information.

REPLACEMENT FILTERS

The HSR filter Part No. 11001F (11.63" x 8.50" x 0.50" [295mm x 216mm x 13mm])

