

KNHE48 WATER-TO-AIR PANEL-MOUNTED HEAT EXCHANGERS



**NEMA
TYPE 4/4X
MAINTAINED**

TECHNICAL DATA

Model	Volts	Power		Maximum Inlet Water Temp.	Performance Watts/°F (Watts/°C)			
		Amps	Watts	°F (°C)	1GPM	2GPM	3GPM	4GPM
KNHE48	115	2.2	255	85 (29)	90 (162)	135 (243)	150 (270)	165 (297)
K2NHE48	230	1.1	255	85 (29)	90 (162)	135 (243)	150 (270)	165 (297)

Model	BTU/H (Watts) @				Approx. Weight lbs. (kg.)
	1GPM	2GPM	3GPM	4GPM	
KNHE48	13,819 (4,050)	20,729 (6,079)	23,032 (6,750)	25,335 (7,425)	89 (40)
K2NHE48	13,819 (4,050)	20,729 (6,079)	23,032 (6,750)	25,335 (7,425)	89 (40)

60 Hz. operation. For 50 Hz. operation, consult Kooltronic.



Find additional information on this model at kooltronic.com, or use the Technical Documents QR code below.

Technical Documents

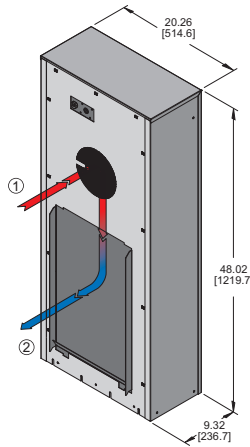

STANDARD FEATURES

- Closed-Loop Cooling
- Epoxy-Coated Heat Exchanger Coils
- NEMA 4/4X Rating Maintained (UL50)
- Stainless Steel Shell
- UL/CUL Listed

ACCESSORIES AND OPTIONS

- Automatic Water Flow Control
- High Water Level Detector
- Internal corrosion protection
- Low Airflow Detector
- Other voltages and frequencies
- Special materials or finishes
- Special motors, line cords, or connectors
- Temperature Alarm

PERFORMANCE*

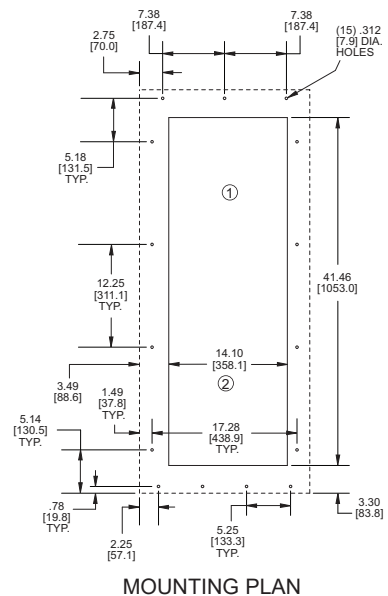
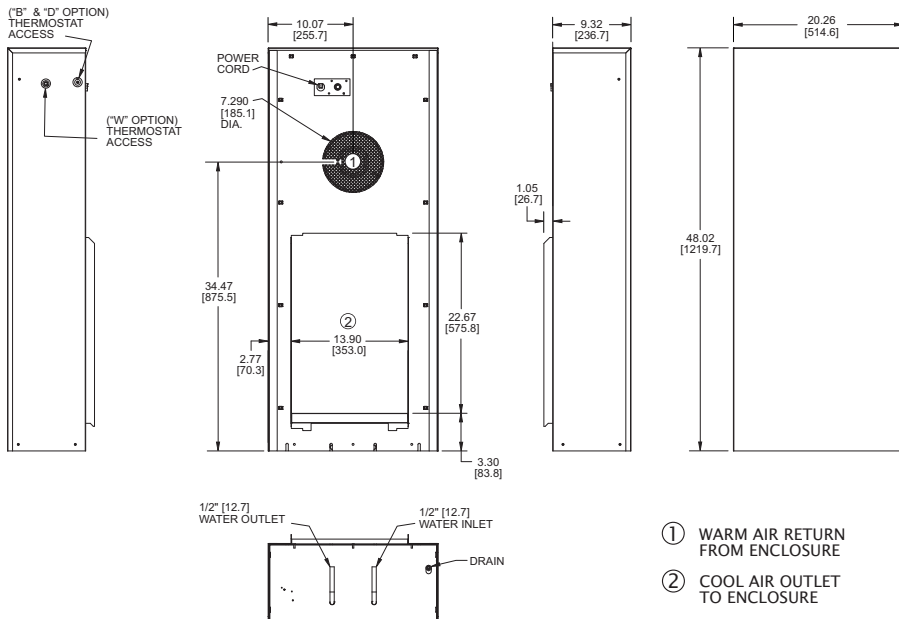
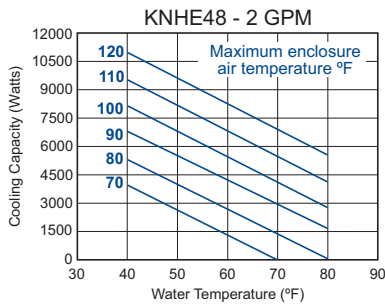

Dimensions, inches [mm], are for reference only and subject to change.

knhe48.qxd (10/23) (CDR: 20532)

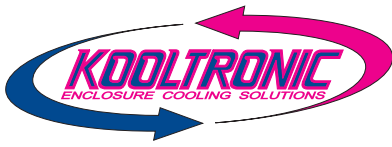

KNHE48 WATER-TO-AIR PANEL-MOUNTED HEAT EXCHANGERS

DESCRIPTION

KOOLTRONIC **Water-to-Air Heat Exchangers** provide uniform cooling in a closed-loop system where a reliable source of clean, cool water is available. The **KNHE48** is designed primarily for use in harsh environments with cooling requirements in excess of the capabilities of **Air-to-Air Heat Exchangers** or **Air Conditioners**. They are particularly useful in highly contaminated environments that would require very frequent cleaning or changing of ambient air filters, or require frequent cleaning of the Heat Exchanger core. KOOLTRONIC **KNHE48 NEMA 4/4X Water-to-Air Heat Exchangers** can furnish greater cooling capacities than air-to-air models, depending on water temperature and rate of flow. **Ambient air is sealed out; heat transfer surfaces remain clean.**

The higher cooling capacity of the **KNHE48** depends on the temperature of the cooling water. Thus, if the water is cold enough, the temperature of the air delivered to the electronics cabinet can actually be lower than that provided by air conditioners, at less cost. This unit combines the best features of the **NEMA 4/4X Heat Exchangers** with the increased cooling capacity offered by the water-to-air models.

KOOLTRONIC also designs and manufactures a variety of Heat Exchangers to meet *unique* specifications. We invite your inquiries about our modification and custom-design capabilities.

STANDARD FEATURES

CLOSED-LOOP COOLING: The enclosure interior airflow system is isolated from the ambient airflow system. No ambient air can invade the cool, dehumidified sensitive component compartment.

EPOXY-COATED HEAT EXCHANGER COILS: Heat Exchanger coils in the KNHE48 are epoxy-coated. This coating will withstand 1000 hours of salt spray per the ASTM B 117 test method. Also see Stainless Steel Cabinet or Integrity NEMA 4/4X Air Conditioners. **NOTE:** Severe operational environments such as waste water treatment and salt spray are likely to cause corrosion failure over a period of time regardless of coating. **Warranty:** Corrosive conditions may effect the warranty coverage. Consult factory for warranty limitations in corrosive environments. **NOTE:** For additional corrosion protection options, contact factory.

PRECISION BALL-BEARING MOTORS: All blower motors are UL/CSA Recognized and include automatic-reset thermal overload protection and double-sealed or double-shielded precision ball bearings. Special permanent lubricants perform over a broad temperature range: -20°F [-28.9°C] to 250°F [121.1°C]. Consult KOOLTRONIC for motors designed to meet military or other extreme environmental specifications.

BLOWERS: All centrifugal blowers are Kooltronic-designed and built, to provide optimum airflow and pressure for each Heat Exchanger design.

RUGGED CONSTRUCTION: Precision-engineered heavy gauge steel construction of all shells and blowers insures Heat Exchangers will stand up under tough applications.

STAINLESS STEEL SHELL: For applications in corrosive or other hostile environments.

POWER: Available in 115 VAC, 50/60 Hz and 230 VAC, 50/60 Hz.

POWER CORD: All 115 and 230VAC models are supplied with six-foot three-wire cord with plug. DC units have three-wire cords without plugs for direct wiring to power source. Special lengths and/or plugs are available.

GASKETING: All units are fully gasketed for tight, leakproof installation, in compliance with the NEMA 4/4X Enclosure Rating.

UL/CUL LISTED: All **KNHE48** models are **UL/CUL Listed**

ACCESSORIES AND OPTIONS**

FACTORY-INSTALLED OPTIONS:

AUTOMATIC WATER FLOW REGULATING VALVE: As supply water temperature and/or heat variances occur, this valve senses the return air temperature and modulates the water flow to provide cooling at the adjustable pre-set level.

Append "W" to Part No.

TEMPERATURE ALARM: A thermostat is mounted inside the cabinet and attached to a sensor in the warm air return. When the air temperature increases to the set point, a signal is sent to a terminal block. User-installed wiring from the terminal block to local and/or remote warning devices (*light, bell, siren, etc.*) can be for normally open or closed operation.

Append "B" to Part No.

HIGH WATER LEVEL DETECTOR PACKAGE: Closes water-supply valve to prevent flooding if excess water accumulates in the drain pan. Signal circuit activates a user-supplied warning device. The low voltage power for the signal circuit is supplied by the user.

Append "C" to Part No.

INTERNAL CORROSION PROTECTION: This protection increases reliability in hostile environments. This protection for the cooling system consists of an air cured coating applied to the brazed joints, providing a degree of protection from corrosive environments. This coating will withstand 1000 hours of salt spray per ASTM B 117 test method. **NOTE:** Severe operational environments such as waste water treatment and salt spray are likely to cause corrosion failure over a period of time regardless of coating. This coating provides protection to the external portion of the coil and does not protect from any corrosive elements in the cooling water used internally. **Warranty:** Corrosive conditions may affect the warranty coverage. Consult factory for warranty limitations in corrosive environments. **NOTE:** For additional corrosion protection options, contact factory.

Append "H" to Part No.

LOW AIRFLOW DETECTOR: Similar to the Airflow Switch described as a Blower Accessory, this switch is installed in a suitable location in the heat exchanger to detect loss of airflow, and sends a signal to a terminal block, through which user-installed wiring and warning devices are activated.

Append letter "M" to Part No.

OTHER VOLTAGES AND FREQUENCIES**

SPECIAL MATERIALS OR FINISHES**

SPECIAL MOTORS, LINE CORDS OR CONNECTORS**

**Contact KOOLTRONIC for information.

