

KNHX32 AIR-TO-AIR PANEL-MOUNTED HEAT EXCHANGERS



**NEMA
TYPE 4/4X
MAINTAINED**



TECHNICAL DATA*

Model	Normally in Stock	Volts	Power		Maximum Temperature °F		Performance Watts/°F (Air In)	Approx. Weight (lbs.)
			Amps	Watts	Enclosure	Ambient		
KNHX32	Yes	115	1.5	160	160	-20 to 131	21	70
K2NHX32		230	1.1	260	160	-20 to 131	21	70

* 60 Hz. operation. For 50 Hz. operation, consult Kooltronic.

STANDARD FEATURES

- Closed-Loop Near-Ambient Cooling
- Epoxy-coated aluminum element
- Filter
- Gasketed Flanges
- NEMA 4/4X Rating Maintained (UL50)
- Stainless Steel Shell
- UL/CUL Listed

ACCESSORIES AND OPTIONS

- Filter Recoating Adhesive
- Lifting Eyes
- Low Airflow Detector
- Other voltages and frequencies
- Replacement Filters
- Special materials or finishes
- Special motors, line cords, or connectors
- Temperature Alarm

PERFORMANCE*

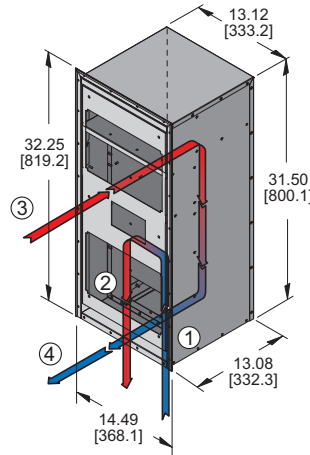
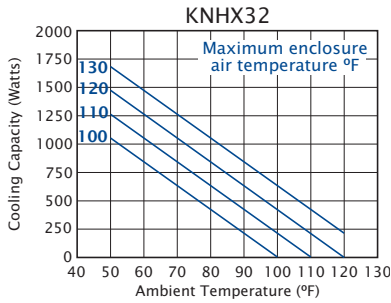

Find additional information on this model at kooltronic.com, or use the Technical Documents QR code below.

Technical Documents



- 1 FILTERED CONDENSER AIR INLET (Ambient Air In)
- 2 CONDENSER OUTLET (Warm Ambient Air Out)
- 3 WARM AIR RETURN FROM ENCLOSURE
- 4 COOL AIR OUTLET TO ENCLOSURE

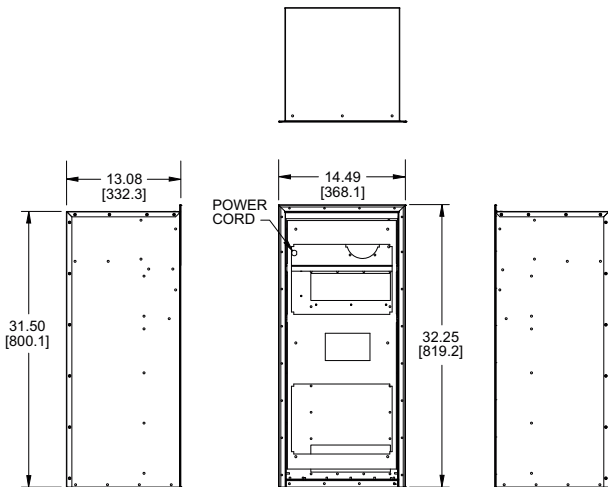

UNIT MUST BE 12" [300mm] MINIMUM ABOVE FLOOR FOR FILTER ACCESS

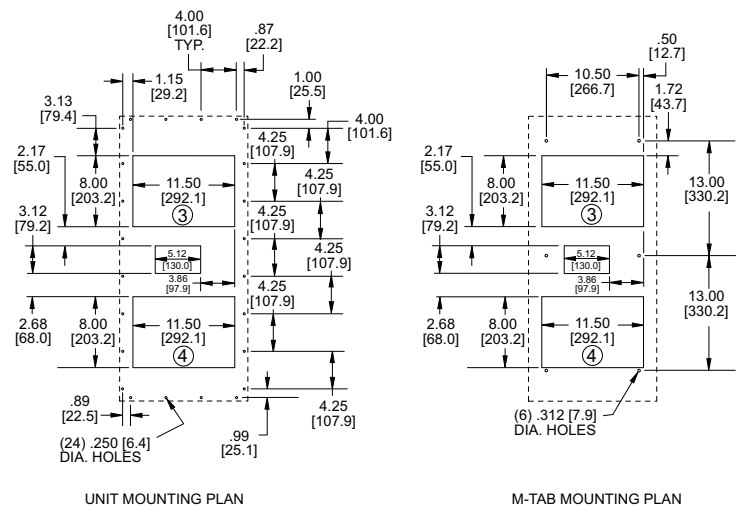
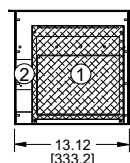

Dimensions, inches [mm], are for reference only and subject to change.

knhx32.qxd (6/8/23) (CDR: 20498)

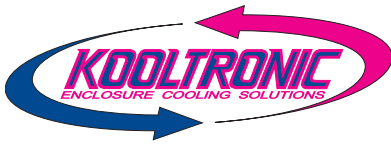

KNHX32 AIR-TO-AIR PANEL-MOUNTED HEAT EXCHANGERS

DESCRIPTION

KOOLTRONIC *Integrity NEMA 4/4X Heat Exchangers* are intended to complement the *Integrity NEMA 4/4X Air Conditioner* product line for those applications that require the protection of closed-loop cooling, but can tolerate operating temperatures somewhat above the ambient.

Tested and rated by Underwriters Laboratories, these uniquely designed (Patent Pending) stainless steel Heat Exchangers provide a clean, cool internal environment and also protect against the hazards specified for both **Indoor** and **Outdoor NEMA 4 and 4X Enclosures**.

These units can be mounted interchangeably with KOOLTRONIC *Integrity NEMA 4/4X Air Conditioners* for maximum flexibility in selection, upgrading or reducing cooling performance, if requirements change. The outer cover mounting holes as well as the cool air discharge and heated air return cutouts are identical (except cool air discharge of the 32" model), so that either type of cooling unit could be used.

More powerful ambient-side blowers are used than in comparably sized standard *KXHE* and *KXNP* models, to overcome the added static pressure caused by the special baffles and dampers required to comply with NEMA 4/4X sealing and performance standards.

For extreme ambient temperatures and/or severely contaminated environments, the use of *Water-to-Air Heat Exchangers* or either *Air-Cooled* or *Water-Cooled Air Conditioners* is recommended.

KOOLTRONIC also designs and manufactures a variety of Heat Exchangers to meet *unique* specifications. We invite your inquiries about our modification and custom-design capabilities.

STANDARD FEATURES

CLOSED-LOOP COOLING: The enclosure interior airflow system is isolated from the ambient airflow system. No ambient air can invade the cool, dehumidified sensitive component compartment.

EPOXY-COATED ELEMENT: Fabricated to the same standards as the uncoated convoluted aluminum elements, these are made from epoxy-coated aluminum stock that passed 1000 hour salt spray testing.

PRECISION BALL-BEARING MOTORS: All blower motors are UL/CSA Recognized and include automatic-reset thermal overload protection and double-sealed or double-shielded precision ball bearings. Special permanent lubricants perform over a broad temperature range: -20°F [-28.9°C] to 250°F [121.1°C]. Consult KOOLTRONIC for motors designed to meet military or other extreme environmental specifications.

BLOWERS: All centrifugal blowers are Kooltronic-designed and built, to provide optimum airflow and pressure for each Heat Exchanger design.

RUGGED CONSTRUCTION: Precision-engineered heavy gauge steel construction of all internal structures and blowers insures Heat Exchangers will stand up under tough applications.

STAINLESS STEEL SHELL: For applications in corrosive or other hostile environments.

POWER: Available in 115 VAC, 60 Hz and 230 VAC, 50 Hz or 60 Hz.

FILTERS: The filters included with all Heat Exchangers consist of a multi-layer grid of sturdy, corrugated aluminum in a one-piece aluminum frame. Filters must be kept free of accumulations, to prevent reduction or loss of performance and/or damage to equipment.

POWER CORD: All 115 and 230VAC models are supplied with six-foot three-wire cord with plug. BLDC units have three-wire cords without plugs for direct wiring to power source. Special lengths and/or plugs are available.

GASKETING: All units are fully gasketed for tight, leakproof installation, in compliance with the NEMA 4/4X Enclosure Rating.

UL LISTED: All *KNHX32* models are *UL Listed*.

ACCESSORIES AND OPTIONS**

FACTORY-INSTALLED OPTIONS:

AIRFLOW SWITCH**

LIFTING EYES: A pair of heavy-gauge steel lifting eyes, attached to the side panels, assist in positioning units.

Append letter "K" to Part No.

LOW AIRFLOW DETECTOR: Similar to the Airflow Switch described as a Blower Accessory, this switch is installed in a suitable location in the heat exchanger to detect loss of airflow, and sends a signal to a terminal block, through which user-installed wiring and warning devices are activated.

Append letter "M" to Part No.

OTHER VOLTAGES AND FREQUENCIES**

SPECIAL MATERIALS OR FINISHES**

SPECIAL MOTORS, LINE CORDS OR CONNECTORS**

**Contact KOOLTRONIC for information.

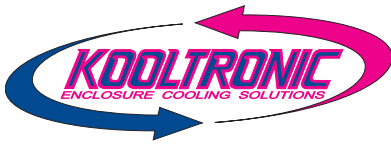

KNHX32 AIR-TO-AIR PANEL-MOUNTED HEAT EXCHANGERS

ACCESSORIES AND OPTIONS** (continued)

CUSTOMER-INSTALLED OPTIONS:

FILTER RECOATING ADHESIVE: This compound is a superior product for recoating filters after washing. The adhesives penetrate dirt layers to keep the filter surface tacky for longer effective performance between washings.

Part No. A-16 - 10 ounce container.

REPLACEMENT FILTERS: All KOOLTRONIC filters consist of a multi-layer grid of sturdy corrugated aluminum, securely held in a one-piece aluminum frame. Filters are required wherever air is drawn into an electronics enclosure or related cooling equipment to keep internal parts as clean as possible.

A non-drying adhesive coating traps a high percentage of particulate matter. These filters are reuseable, they may be washed and recoated with the appropriate filter recoating adhesive. Replacements are available for those which become damaged or otherwise non-serviceable.

Part No. 800F (10.38" x 10.38" x 0.50" [264mm x 264mm x 13mm])

TEMPERATURE ALARM: A thermostat is mounted inside the cabinet and attached to a sensor in the warm air return. When the air temperature increases to the set point, a signal is sent to a terminal block. User-installed wiring from the terminal block to local and/or remote warning devices (*light, bell, siren, etc.*) can be for normally open or closed operation.

Append letter "B" to Part No.

**Contact KOOLTRONIC for information.

HOW TO ORDER

Specify model number. NOTE: Accessories and Options may affect model number, contact KOOLTRONIC for information.

For assistance in model selection, refer to the Heat Exchanger Sizing and Selection Guide, contact KOOLTRONIC, or use one of our design aid software programs, available FREE.

CALL 1-800-321-KOOL (5665)
or FAX 609-466-1114

POPULAR MODELS ARE
STOCKED AND READY TO SHIP

